

Precision Pressure Transducer - Explosion-Proof PPTe

APPLICATIONS

- Process Control
- Chemical Refineries
- Oil and Gas
- Paper and Pulp



Class I, Div I,
Groups B,C,D
Class II/III, Div I,
Groups E, F, G
Temp. T6
Max Ambient = 70°C
Type 4X

± 0.10% Accuracy from -40 to 85°C

Digital and Analog

Hermetically Sealed

Honeywell's PPTe offers an explosion-proof pressure transducer where protection in hazardous locations is critical. It combines proven silicon sensor technology with microprocessor-based signal conditioning to provide an extremely smart pressure transducer. Designed with a hermetically sealed, stainless steel construction, the PPTe operates in severe vibration, thermal and mechanical shock environments. The PPTe has many software features that support a wide range of applications.



ISO 9001

FEATURES AND BENEFITS

<p>High Accuracy: ± 0.10% FS typical accuracy from -40 to 85°C</p>	<p>Simplifies system design—no additional signal compensation needed to gain the benefits of a very accurate sensor.</p>	
<p>Smart, Digital Sensing & Control</p>	<p>Efficient data acquisition—connect up to 89 units on a multidrop bus using built-in RS485 capability. Easily interfaces directly to a PC via communication ports. Closes the loop—smart PPT makes control decisions.</p>	
<p>Versatile and Configurable</p>	<p>Works with existing and new systems—all units have 0-5V analog and either RS-232 or RS-485 digital outputs. Isolation diaphragms handle most media—harsh gases or liquids. Operates in severe vibration, thermal and mechanical shock environments. Optimizes output—user-configurable pressure units, sampling, update rate. Flags problems—internal diagnostics set flags, provide alarms.</p>	
<p>User-Selectable Software Features</p>	<p>Baud Rate, Parity Setting Continuous Broadcast ASCII or Binary Output Sensor Temperature Output (°C or °F)</p>	<p>Deadband, Sensitivity Tare Value Configurable Analog Output And more...</p>

SPECIFICATIONS

Performance Specifications⁽¹⁾

Accuracy: (from -40 to 85°C)
 Digital: ±0.10% FS typ, ±0.20% FS max.⁽²⁾
 Analog: ±0.12% FS typ, ±0.24% FS max.⁽²⁾
 Temperature: ±1°C (at sensing element)
Temperature Range:
 Operating -40 to 85°C (-40 to 185°F)
 Storage: -55 to 90°C (-67 to 194°F)
Sample Rate⁽⁴⁾: 8.33ms to 51.2 min
Resolution:
 Digital: Up to 0.0011% FS
 Analog: 1.22mV steps (12 bits)
Response Delay:
 (1000/update rate) + 1ms, minimum 17ms

Mechanical Specifications

Pressure Ranges and Type:
 See ordering information
Pressure Units⁽⁴⁾: atm, bar, cmwc, ftwc, hPa, inHg, inwc, kg/cm², KPa, mBar, mmHg, MPa, mwc, psi, user, lcom, pfs
Media Compatibility:
 Suitable for media compatible with 316 stainless steel (Consult factory for Hastelloy diaphragm).
Weight: 22 oz. (624 gm) NPT w/pigtail style

Electrical Specifications

Output:
 RS-232 Digital w/0-5V Analog⁽⁴⁾
 RS-485 Digital w/0-5V Analog⁽⁴⁾
Power Requirements:
 Supply Voltage: 6.0 to 30 VDC
 Operating Current: 19-27mA
Bus Addressing⁽⁴⁾: Address up to 89 units.
Baud Rate⁽⁴⁾: 1200, 2400, 4800, 9600, 14400, 19200, 28800
Industrial Emissions and Immunity:
 Meets IEC 61326

Environmental Features⁽³⁾

Overpressure: 3x FS, maximum 6000 psi
Burst Pressure: 3x FS, maximum 8500 psi
Mechanical Shock: 1500g, 0.5ms half sine
Temp Shock: 24 1-hr cycles, -40 to 85°C
Vibration: 0.5in or 20G's, 20Hz - 2K Hz

(1) Accuracy is the sum of worst case linearity, repeatability, hysteresis, thermal effects and calibration errors from -40 to 85°C. Typical is the average of absolute value of errors at all pressures and temperatures. Calibration is traceable to NIST.
 (2) Tighter accuracy may be available on some models. Consult factory.
 (3) Exposure to overpressure will not permanently affect calibration or accuracy of unit. Exceeding burst pressure may result in media escape. Mechanical Shock tested per MIL-STD-883D, M2002.3, Cond B. Vibration tested per MIL-STD-883D, M2007.2, Cond A.
 (4) User - Configurable.

CASE OUTLINE

Signal Name	
A	RS-232 (TD) / RS-485 (B)
B	RS-232 (RD) / RS-485 (A)
C	Case Ground
D	Common Ground (GD)
E	DC Power In
F	Analog Output

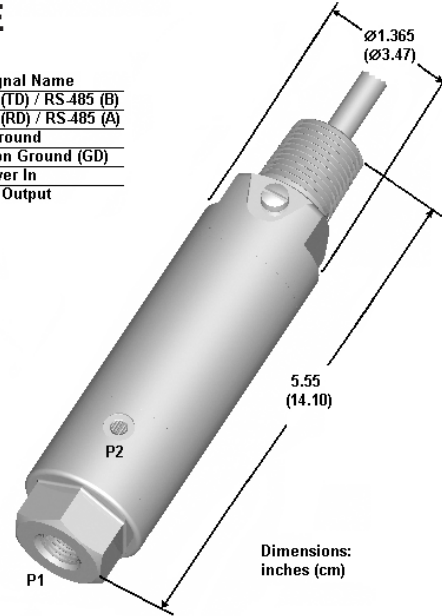

ORDERING INFORMATION

Example: PPTE1000AP2VDC

PPTE Precision Pressure Transducer - Explosion-Proof

FULL SCALE PRESSURE RANGE

	Absolute	Gauge
0015	15 PSI	n/a
0020	20 PSI	20 PSI
0040	40 PSI	40 PSI
0100	100 PSI	100 PSI
0300	300 PSI	300 PSI
0500	500 PSI	500 PSI
1000	1000 PSI	1000 PSI
1500	1500 PSI	1500 PSI
3000	3000 PSI	3000 PSI

Type	P1 Pressure	P2 Pressure
A Absolute	0 (vacuum) to FS	N/A
G Gauge	Reference to FS	Reference

P1 PRESSURE CONNECTION

P 1/4 - 18 NPT (internal)

OUTPUTS

2V RS-232 digital, 0-5V analog
 5V RS-485 digital, 0-5V analog

ELECTRICAL CONFIGURATION AND CONNECTION

D 1/2 - 14 NPT external w/4ft pigtail cable

EXPLOSION-PROOF CERTIFICATION

C CSA, Canadian Standards Association
 Class I, Div I, Groups B, C, D; Class II/III, Div I, Groups E, F, G
 F FM, Factory Mutual
 Class I, Div I, Groups B, C, D; Class II/III, Div I, Groups E, F, G

PPTE 1000 A P 2V D C

Honeywell reserves the right to make changes to any products or technology herein to improve reliability, function or design. Honeywell does not assume any liability arising out of the application or use of any product or circuit described herein; neither does it convey any license under its patent rights nor the rights of others. Covered by one or more of the following US Patents: 4,918,992; 4,788,521; and 5,948,988.

