

Pressure Relief Valve Reference Drawing

Date Prepared: 2003-11-20 11:36

PSV Identification

Customer	Requisition #	Job #	Job Description	
		+10475		
Tag #	Tag Description	Tag Status	P / ID	
PSV-DW-01		Valve Selected		
ASME Code	Fluid State	Resolved Area	Rupture Disk Coeff.	NACE
ASME Sec. VIII	Gas (Volume)	0.11179 in ²	No Rupture Disk, 1	No
Operating Pressure	Set Pressure	Constant Back P.	Variable Back P.	Cold Diff. Test P.
175 PSIG	200 PSIG	0 PSIG	0 PSIG	200 PSIG
Operating Temp.	Relief Temp.	Operating to Set %	Over Pressure	Percent Over P.
120 °F	120 °F	87.5 %	20 PSIG	10 %

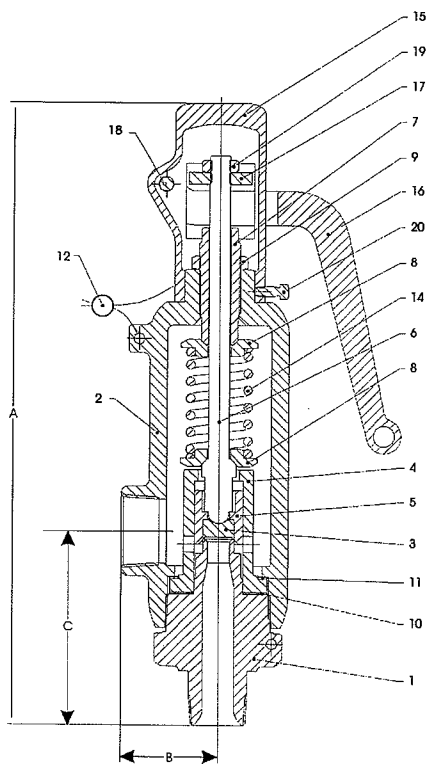

Farris 27DA23-M70

API Letter	API Area	ASME Area
		0.125 in ²

	Size	Rating	Facing
Inlet:	0.75 in		MNPT
Outlet:	1.00 in		FNPT

Valve Design	Cap Constrn	Test Gag
Conventional	Open Lever	No
Max. Rel. Cap.	React. Force	Noise
447.26 std ft ³ /min	28.11 lbs	99.266 dBa

Materials

Body (1)	Bonnet (2)
316 ss	Carbon Steel
Nozzle (1)	Disc (3)
316 ss	316 ss
Guide (4)	Spring (13)
316 ss	316 ss

Dimensions

Weight	Dimension A	Dimension B
8 lb	11 1/4 in	1 3/4 in
Dimension C		
3 9/16 in		

Pressure Relief Valve Reference Drawing

Date Prepared: 2003-11-20 11:40

PSV Identification

Customer	Requisition #	Job #	Job Description	
		+10475		
Tag #	Tag Description		Tag Status	P / ID
PSV-DW-01			Valve Selected	
ASME Code	Fluid State	Resolved Area	Rupture Disk Coeff.	NACE
ASME Sec. VIII	Gas (Volume)	0.15055 in ²	No Rupture Disk, 1	No
Operating Pressure	Set Pressure	Constant Back P.	Variable Back P.	Cold Diff. Test P.
175 PSIG	200 PSIG	0 PSIG	0 PSIG	200 PSIG
Operating Temp.	Relief Temp.	Operating to Set %	Over Pressure	Percent Over P.
120 °F	120 °F	87.5 %	20 PSIG	10 %

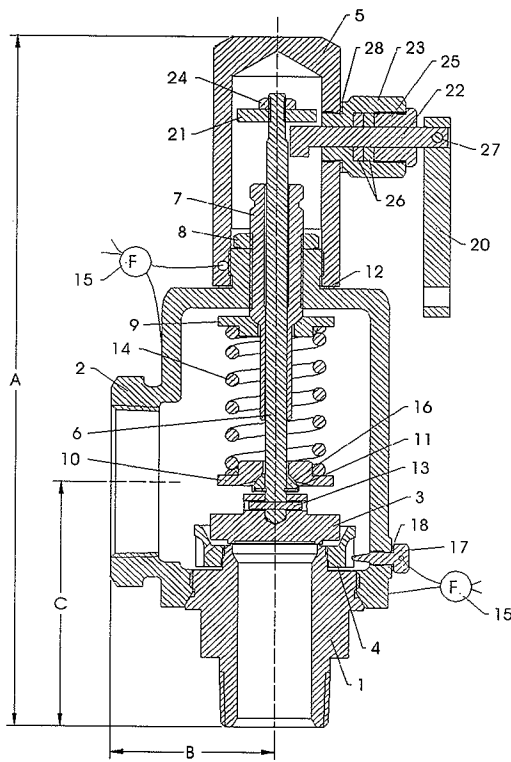

Farris 285003-M40

API Letter	API Area	ASME Area
		0.240 in ²

	Size	Rating	Facing
Inlet:	0.75 in		MNPT
Outlet:	1.00 in		FNPT

Valve Design	Cap Construction	Test Gag
Conventional	Packed Lever	No
Max. Rel. Cap.	React. Force	Noise
637.67 std ft ³ /min	44.991 lbs	100.81 dBa

Materials

Body (1)	Bonnet (2)
316 ss	Carbon Steel
Spring (17)	
316 ss	

Dimensions

Weight	Dimension A	Dimension B
3 1/2 lb	8 in	1 11/16 in
Dimension C		
2 5/8 in		

O-ring Selection



PRESSURE & TEMPERATURE LIMITS O-RING SEAT VALVE

The 2700 Series is available with an optional O-ring seat which minimizes fugitive emissions and costly product loss. This optional seat construction provides zero bubbles per minute leakage at 90%

of set pressure per API Standard 527. The Tables below list the set pressure and temperature range for both the elastomer and Teflon seat options.

Orifice	Pressure Range, PSIG ¹		Pressure Range, Bar G ²	
	Elastomer Seat	Teflon Seat	Elastomer Seat	Teflon Seat
C High Pressure	15 to 1480 —	800 to 2500 2501 to 5000	1.00 to 102 —	55.1 to 172 172.1 to 345
D High Pressure	15 to 1480 —	800 to 1600 1601 to 5000	1.00 to 102 —	55.1 to 110 110.1 to 345
E	15 to 2500	600 to 2500	1.0 to 172	41.3 to 172
F	15 to 1480	600 to 1600	1.0 to 102	41.3 to 110
G	15 to 1000	200 to 1000	1.0 to 69	14 to 69

MATERIAL AVAILABILITY		
Material	Temperature Range ¹	
	°F	°C
Viton®	-20° to +450°	-29° to +232°
Buna N	-20° to +250°	-29° to +121°
EPR	0° to +350°	-18° to +177°
Silicone	-150° to +450°	-101° to +232°
Kalrez®	-20° to +550°	-29° to +289°
Teflon	-300° to +500°	-184° to +260°

General Notes:

1. Maximum O-ring set pressure limit cannot exceed the pressure limit for a given type number and size as indicated in the metal seat selection tables.
2. Temperature range may vary depending on service fluid.
3. Ethylene propylene is suitable for steam service up to 350°F, Teflon up to 500°F.
4. Consult the Farris Factory for other materials.

Selection Table

U.S. CUSTOMARY UNITS: THREADED CONNECTIONS-MNPT X FNPT

Orifice Area Sq. In.	Valve Size Inlet x Outlet	Type Number	Maximum Set Pressure, PSIG	Max. Back Pressure PSIG at 100° F	Materials	
			-20° F to 750° F		Body/Bonnet	Spring
0.068	1/2 x 1	27CA13-M20	1600	400	316 St. St. / Carb. St.	Stainless Steel
	3/4 x 1	27CA23-M20	2500			
	3/4 x 1	27CA23H-M20	5000			
	1 x 1	27CA33-M20	2500			
	1 x 1	27CA33H-M20	6500			
0.125	1/2 x 1	27DA13-M20	1600	400	316 St. St. / Carb. St.	Stainless Steel
	3/4 x 1	27DA23-M20	1600			
	3/4 x 1	27DA23H-M20	5000			
	1 x 1	27DA33-M20	1600			
	1 x 1	27DA33H-M20	5000			
0.223	1 x 1 1/2	27EA34-M20	2500	400	316 St. St. / Carb. St.	Stainless Steel
0.350	1 1/2 x 2	27FA45-M20	1600	400	316 St. St. / Carb. St.	Stainless Steel
0.573	1 1/2 x 2 1/2	27GA46-M20	1000	400	316 St. St. / Carb. St.	Stainless Steel

Viton and Kalrez are registered trademarks of DuPont Dow Elastomers.

Bill of Materials - Conventional



Complies with
ASME Boiler
& Pressure
Vessel Code,
Section VIII

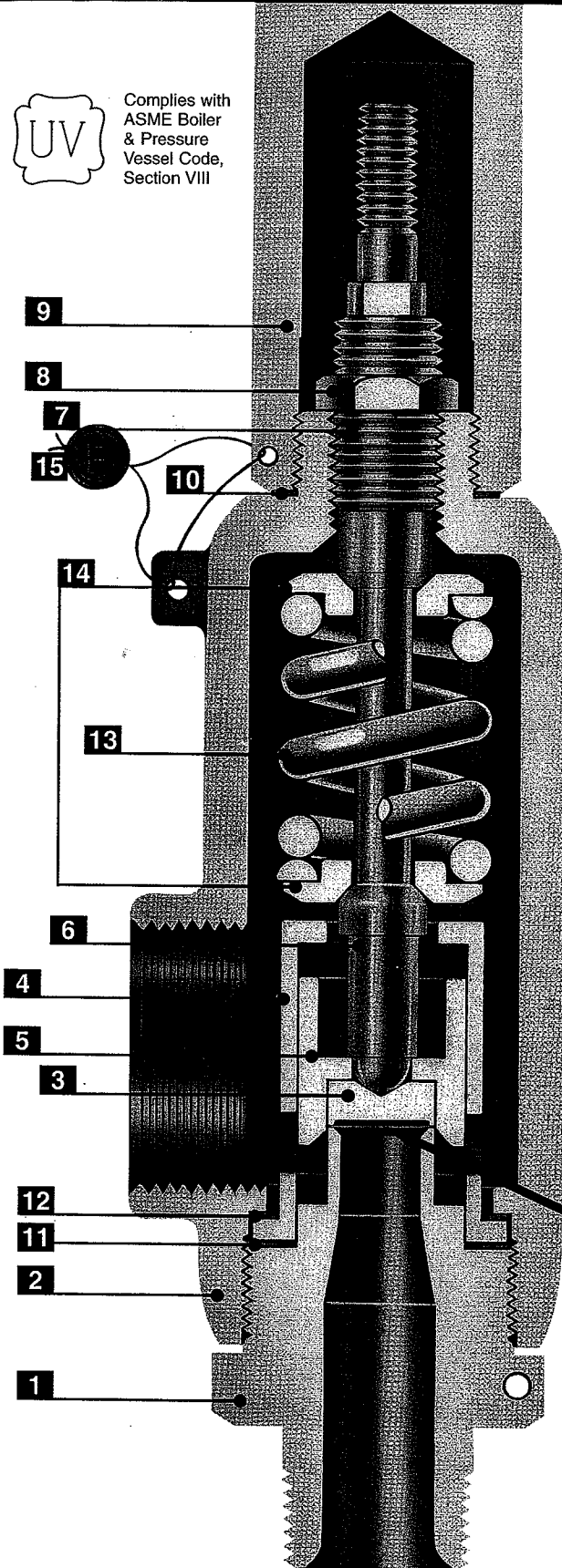

Item No.	Part Name	Standard Material
1	Body	SA-351, Gr. CF8M St. St. or SA-479 Type 316 St. St.
2	Bonnet	SA-216, Gr. WCB, Carb. St.
3	Disc	316 St. St.
4	Guide	316 St. St.
5	Disc Holder	316 St. St.
6	Stem	316 St. St.
7	Spring Adj. Screw	316 St. St.
8	Jam Nut	316 St. St.
9	Cap, Plain Screwed	Carbon Steel
10	Cap Gasket	316 St. St.
11	Body Gasket	316 St. St.
12	Guide Gasket	316 St. St.
13	Spring (-20° to +750°F)	Stainless Steel
14	Spring Buttons	316 St. St.
15	Wire Seal	St. St. Wire / Lead Seal
16	Nameplate (Not Shown)	Stainless Steel
17	Welding Nipple (Inlet)	316 St. St.
18	Welding Nipple (Outlet)	Carbon Steel
19	Lap Joint Stub End (Inlet)	316 St. St.
20	Lap Joint Stub End (Outlet)	Carbon Steel
21	Lap Joint Flange (Inlet)	Carbon Steel
22	Lap Joint Flange (Outlet)	Carbon Steel

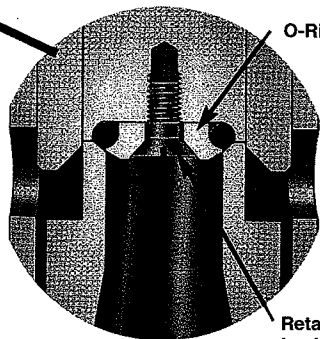

O-Ring Design
(Optional)

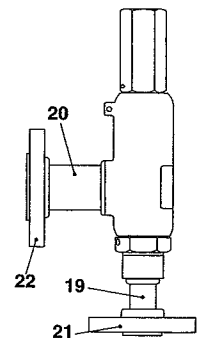
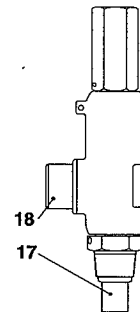

Series 2850

Pressure Relief Valves for Air,
Steam, Vapor & Liquid Service



- Built in conformance to ASME Code Section VIII for Air, Steam, and Vapor Service.
- Set pressures to 300 psig.
- Stainless steel body and trim.

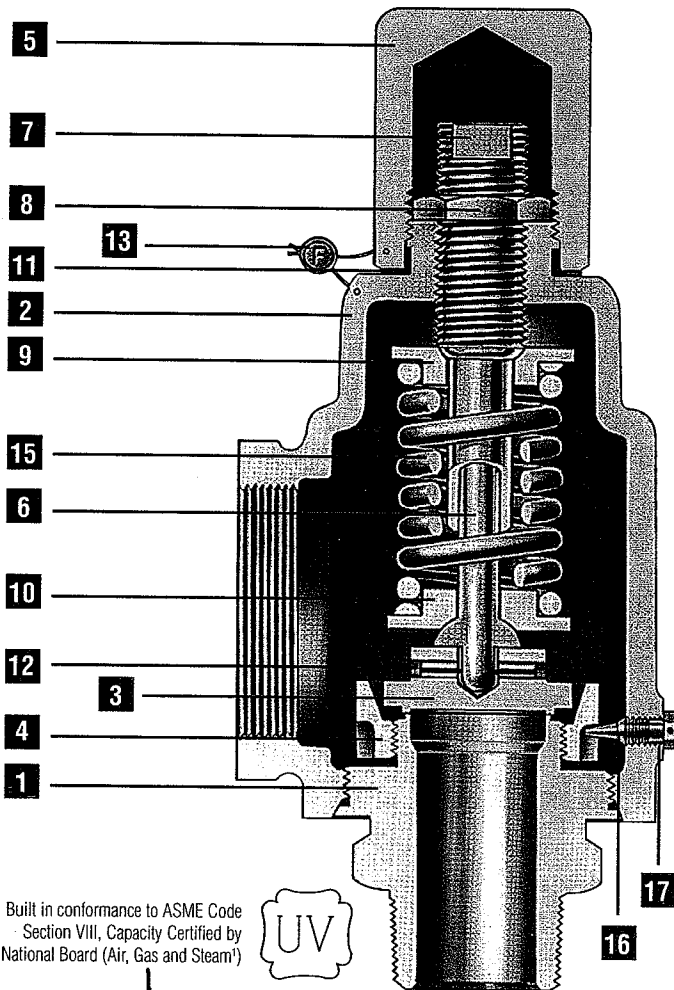

Built in conformance to ASME Code Section VIII, Capacity Certified by National Board (Air, Gas and Steam)

Bill of Materials		
Item No.	Part Name	Material 2850 & 2852
1	Body	SA-479 Type 316 St. St. or SA-351 Gr. CF8M St. St.
2	Bonnet	SA-216 Gr. WCB Carbon Steel
3	Disc	316 St. St.
4	Blow Down Ring	Stainless Steel
5	Cap	Carbon Steel
6	Stem	Stainless Steel
7	Spring Adj. Screw	Stainless Steel
8	Jam Nut	Stainless Steel
9	Spring Button (Upper)	Stainless Steel
10	Spring Button (Lower)	Stainless Steel
11	Cap Gasket	Stainless Steel
12	Grooved Pin	Stainless Steel
13	Wire Seal	Stainless Steel Wire/Lead Seal
14	Nameplate (not shown)	Stainless Steel
15	Spring	See Selection Table
16	Blow Down Ring Lock Screw	Stainless Steel.
17	Blow Down Ring Lock Screw Gasket	316 St. St.

Selection Table MNPT INLET X FNPT OUTLET

Type Number	Maximum Set Pressure, psig				Inlet Temp Range °F	Maximum Back Pressure psig at 100°F	Materials	
	Inlet	3/4	1	1-1/2			Body/ Bonnet	Spring
	Outlet	1	1-1/2	2				
2850	300	300	300	-20 to 400	50	316 St. St./ Carbon Steel	316 St. St.	
2852	300	300	300	400 to 750			Chrome Alloy Rust Proofed	

General Notes:

1. Test lever required for air, steam, and hot water (above 140°F) service. For packed lever, add PKD to the Type Number. Example: 2850-PKD. For test gag, add W/TG.
2. For 1/2" x 1" size, see 1890 Series Catalog.
3. Also suitable for liquid service where ASME Code certification is not required.

Farris Engineering

Division of Curtiss-Wright Flow Control Corporation





Capacity Tables: ASME PRESSURE VESSEL CODE (UV)

NON-CODE

AIR 10% OVERPRESSURE Capacities in Standard Cubic Feet Per Minute at 60° F			
Set Pressure (psig)	3/4"	1"	1-1/2"
15	94	161	375
20	108	185	433
40	168	288	674
60	231	396	926
80	294	504	1179
100	357	612	1431
120	420	720	1684
140	483	828	1936
160	546	936	2189
180	609	1044	2441
200	672	1152	2694
220	735	1260	2946
240	798	1368	3199
250	830	1422	3325
260	862	1476	3451
280	925	1584	3704
300	988	1692	3956

STEAM 10% OVERPRESSURE Capacities in Lbs. Per Hour at Saturation Temperature			
Set Pressure (psig)	3/4"	1"	1-1/2"
15	263	451	1054
20	303	520	1216
40	472	810	1893
60	650	1113	2602
80	827	1416	3312
100	1004	1720	4021
120	1181	2023	4730
140	1358	2327	5440
160	1535	2630	6149
180	1712	2933	6859
200	1889	3237	7568
220	2066	3540	8277
240	2243	3844	8987
250	2332	3995	9341
260	2420	4147	9696
280	2597	4450	10406
300	2775	4754	11115

WATER 25% OVERPRESSURE Capacities in U.S. Gallons Per Minute at 70° F			
Set Pressure (psig)	3/4"	1"	1-1/2"
15	10	18	40
20	11	20	45
40	17	30	67
60	21	36	82
80	24	42	95
100	27	47	106
120	29	52	116
140	32	56	125
160	34	60	134
180	36	63	142
200	38	67	150
220	40	70	157
240	41	73	164
250	42	74	168
260	43	76	171
280	45	79	177
300	46	81	184

Notes:
1. Capacities for Air & Steam at 30 psig and below are based on 3 psi overpressure.

Effective Orifice Areas (Sq. In.)		
Inlet Size	Liquids Only	Vapors Gases & Steam
3/4	0.098	0.164
1	0.173	0.281
1 1/2	0.390	0.657

Note: For sizing purposes, the coefficients of discharge K_d are 0.953 for air, gas and vapor; 0.64 for liquids.

Dimensions & Weights (MNPT x FNPT)				
Size	A (max.) All Cap Constructions	B	C	Approx. Weight (lbs.)
3/4 x 1	8	1 11/16	2 5/8	3 1/2
1 x 1 1/2	9 1/16	1 15/16	3	5
1 1/2 x 2	11 15/16	2 7/8	3 11/16	11

Note: All dimensions are in inches.

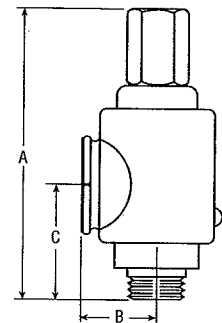

Farris Engineering

Division of Curtiss-Wright Flow Control Corporation

10195 Brecksville Road, Brecksville, OH 44141 USA • Telephone: 440/838-7690 • Fax: 440/838-7699 • www.cwfc.com

Facilities: Brecksville, OH USA, E. Farmingdale NY USA, Brantford, Ontario, Edmonton, Alberta

Offices: worldwide. For a listing of our global sales network, visit our website at www.cwfc.com.

While this information is presented in good faith and believed to be accurate, Curtiss-Wright Flow Control Corporation, Farris Engineering, does not guarantee satisfactory results from reliance on such information. Nothing contained herein is to be construed as a warranty or guarantee, expressed or implied, regarding the performance, merchantability, fitness or any other matter with respect to the products, nor as a recommendation to use any product or process in conflict with any patent. Curtiss-Wright Flow Control Corporation, Farris Engineering, reserves the right, without notice, to alter or improve the designs or specifications of the products described herein.

Printed in USA

9/99-5M-R3