

# Rosemount 2088 Absolute and Gage Pressure Transmitter

**A TRADITION OF EXCELLENCE IN  
PERFORMANCE FROM THE INDUSTRY  
LEADERS**

- Absolute and gage pressure ranges from 0–1.5 psi to 0–4,000 psi (0–0.1 to 0–276 bar)
- 0.10% reference accuracy, including linearity, hysteresis, and repeatability
- 20:1 turndown
- Lightweight, compact size makes for easy installation and handling
- 0.075% High accuracy option

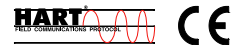

## Content

Specifications . . . . .	page 3
Product Certifications . . . . .	page 5
Dimensional Drawings . . . . .	page 7
Ordering Information . . . . .	page 8
Configuration Data Sheet . . . . .	page 10

## Rosemount 2088

The 2088 Smart Pressure Transmitter is an economical addition to the pressure transmitter line of instruments. The 2088 is designed with reliability, long-term performance, and maintainability in mind. The 2088 maintain a specification conformance of at least  $3\sigma^{(1)}$ . The rugged, reliable performance for which Emerson Process Management transmitters are famous, coupled with Smart capabilities, make these transmitters exceptional values.

The 2088 is available in either gauge or absolute pressure in pressure ranges to 4,000 psi (275 bar). It utilizes a solid-state, polysilicon pressure sensor with a choice of either 316L or Hastelloy isolating diaphragms. The low oil fill of this design has very little temperature effect and outstanding accuracy.

---

(1) *Sigma ( $\sigma$ ) is a statistical symbol to designate the standard deviation from the mean value of normal distribution.*

### Features

The 2088 provides accurate, stable, and reliable pressure measurement in difficult applications. Its small compact design allows it to be directly connected to a process - providing a quick, easy, and cost effective installation.

The 2088 standard process connection is 1/2 inch NPT but a variety of optional connections are available. Optional connections range from multiple threaded connections to our full line of manifolds and remote diaphragm seals that provide solutions for virtually any connection.

The 2088 also features a fully configurable LCD that displays pressure and diagnostic information. The information displayed is directly from the microprocessor which accounts for its accuracy and reliability.

## Rosemount Pressure Solutions

### Rosemount 3051S Series of Instrumentation

Scalable pressure, flow and level measurement solutions improve installation and maintenance practices.

### Rosemount 3095MV Mass Flow Transmitter

Accurately measures differential pressure, static pressure and process temperature to dynamically calculate fully compensated mass flow.

### Rosemount 305 and 306 Integral Manifolds

Factory-assembled, calibrated and seal-tested manifolds reduce on-site installation costs.

### Rosemount 1199 Diaphragm Seals

Provides reliable, remote measurements of process pressure and protects the transmitter from hot, corrosive, or viscous fluids.

### Annubar Flowmeter Series: Rosemount 3051SFA, 3095MFA, and 485

The state-of-the-art, fifth generation Rosemount 485 Annubar combined with the 3051S or 3095MV MultiVariable transmitter creates an accurate, repeatable and dependable insertion-type flowmeter.

### Compact Orifice Flowmeter Series: Rosemount 3051SFC, 3095MFC, and 405

Compact Orifice Flowmeters can be installed between existing flanges, up to a Class 600 (PN100) rating. In tight fit applications, a conditioning orifice plate version is available, requiring only two diameters of straight run upstream.

### Integral Orifice Flowmeter Series: Rosemount 3051SFP, 3095MFP, and 1195

These integral orifice flowmeters eliminate the inaccuracies that become more pronounced in small orifice line installations. The completely assembled, ready to install flowmeters reduce cost and simplify installation.

### Orifice Plate Primary Element Systems: Rosemount 1495 and 1595 Orifice Plates, 1496 Flange Unions and 1497 Meter Sections

A comprehensive offering of orifice plates, flange unions and meter sections that is easy to specify and order. The 1595 Conditioning Orifice provides superior performance in tight fit applications.

# Specifications

## Functional Specifications

### Service

Liquid, gas, and vapor applications

### Ranges

Range	Minimum Span	URL/Max. span/ Sensor Limit
1	1.5 psi (103 mbar)	30 psi (2.1 bar)
2	7.5 psi (517 mbar)	150 psi (10.3 bar)
3	40 psi (2.8 bar)	800 psi (55.2 bar)
4	200 psi (13.8 bar)	4000 psi (275.8 bar)

### Output

Code S: 4–20 mA dc

Code N: 1-5 volt dc, low power

(Outputs are directly proportional to the input pressure)

### Rangedown

20 to 1

### Load Limitations

Reverse polarity protection is standard. Maximum loop resistance is determined by the power supply voltage as described by the following equations:

$$\text{Max. Loop Resistance} = 43.5 (\text{Power Supply Voltage} - 10.5)$$

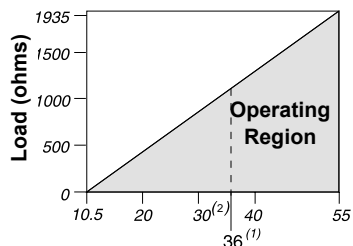

**Power Supply Output Code S (dc Volts)**

Communication requires a minimum loop resistance of 250 ohms.

(1) For hazardous location approvals, power supply must not exceed 36 V.

(2) For GENELEC Ex ia approval, the power supply must not exceed 30 V.

### Power Supply

External power supply required. Transmitter operates on 10.5–36 V dc with no load (6–12V for Low Power). Reverse polarity protection is standard.

### Current Draw

Output Code N:  $\leq 3$  mA without LCD display.

### Overpressure Limits

Range 1: 120 psig max

All other ranges: two times the URL

### Zero Elevation and Suppression

Zero can be suppressed between atmosphere for gage transmitters or 0 psia for absolute transmitters and upper range limit, provided the calibrated span is equal to or greater than the minimum span, and the upper range value does not exceed the upper range limit. For vacuum calibrations, the compound range option is available (Option Code CR).

### Compound Range Capability

Select the Compound Range (CR) option for use in negative gage pressure applications. An enhanced sensor is installed in transmitters with the CR option code.

### Time Response

Time Constant: 200 milliseconds

Dead time:  $< 0.1$  s

Update rate: 20 times per second minimum

### Temperature Limits

Process

Silicone fill sensor:  $-40$  to  $250$  °F ( $-40$  to  $121$  °C)

Inert fill sensor:  $-22$  to  $250$  °F ( $-30$  to  $121$  °C)

Process temperatures above  $185$  °F ( $85$  °C) require derating the ambient limits by a 1.5:1 ratio:

Ambient:

$-40$  to  $185$  °F ( $-40$  to  $85$  °C)

$-4$  to  $175$  °F ( $-20$  to  $80$  °C) with LCD display

Storage:

$-50$  to  $230$  °F ( $-46$  to  $110$  °C)

$-40$  to  $185$  °F ( $-40$  to  $85$  °C) with LCD display

$$\text{Maximum Ambient Temperature in } ^\circ\text{F} : 185 - \frac{(\text{Process Temp} - 185)}{1.5}$$

$$\text{Maximum Ambient Temperature in } ^\circ\text{C} : 85 - \frac{(\text{Process Temp} - 85)}{1.5}$$

### Humidity Limits

0–100% relative humidity

### Volumetric Displacement

Less than  $0.00042$  cm<sup>3</sup>

### Turn-on Time

2.0 seconds, no warm-up required

### Transmitter Security

Activating the transmitter security function prevents changes to the transmitter configuration, including local zero and span adjustments. Security is activated by an internal switch.

## Failure Mode

If self-diagnostics detect a sensor or microprocessor failure, the analog signal is driven either high or low to alert the user. High or low failure mode is user-selectable with a jumper on the transmitter. The values to which the transmitter drives its output in failure mode depend on whether it is factory-configured to *standard* or *NAMUR-compliant* operation. The values for each are as follows:

Standard Operation			
Output Code	Linear Output	Fail High	Fail Low
S	$3.9 \leq I \leq 20.8$	$I \geq 21.75 \text{ mA}$	$I \leq 3.75 \text{ mA}$
N	$0.97 \leq V \leq 5.2$	$V \geq 5.4 \text{ V}$	$V \leq 0.95 \text{ V}$
N with Code C2	$0.78 \leq V \leq 3.44$	$V \geq 4.0 \text{ V}$	$V \leq 0.77 \text{ V}$

Standard Operation			
NAMUR-Compliant Operation			
Output Code	Linear Output	Fail High	Fail Low
S	$3.8 \leq I \leq 20.5$	$I \geq 22.5 \text{ mA}$	$I \leq 3.6 \text{ mA}$

## Performance Specifications

(Zero-based spans, reference conditions, silicone oil fill, and 316L SST isolating diaphragm.)

### Reference Accuracy

- $\pm 0.10\%$  of calibrated span. Includes combined effects of linearity, hysteresis, and repeatability
- $\pm 0.075\%$  of calibrated span (high accuracy option)

### Ambient Temperature Effect

Expressed as a total effect per 50 °F (28 °C)

*Total effect includes zero and span effects.*

$\pm (0.15\% \text{ URL} + 0.15\% \text{ of span})$  from  $-40 \text{ °F}$  to  $185 \text{ °F}$  ( $-40 \text{ °C}$  to  $85 \text{ °C}$ )

### Stability

$\pm 0.10\%$  of URL for 12 months

### Vibration Effect

Less than  $\pm 0.1\%$  of URL when subjected to vibration of: peak to peak constant displacement of 4 mm (5–15 Hz) and constant acceleration of 2 g (15–150 Hz) and 1 g (150–2000 Hz).

### Power Supply Effect

Less than 0.01% of calibrated span per volt

### Mounting Position Effect

Zero shift of up to 1.2 inH<sub>2</sub>O (0.30 kPa), which can be calibrated out. No span effect.

### RFI Effect

Less than  $\pm 0.25\%$  of upper range limit from 20–1000 MHz at 30 V/m with leads in conduit. Less than  $\pm 0.25\%$  of upper range limit from 20–1000 MHz at 10 V/m with unshielded twisted pair (no conduit).

## Transient Protection Limits

### IEEE 587 Category B

- 6 kV Crest ( $1.2 \times 50 \mu\text{s}$ )
- 3 kV Crest ( $8 \times 20 \mu\text{s}$ )
- 6 kV Crest (0.5  $\mu\text{s}$  by 100 kHz)

### IEEE 472

SWC 2.5 kV Crest, 1 MHz waveform

## General Specifications

Tested to IEC 801-3

## Physical Specifications

### Electrical Connection

$\frac{1}{2}$ –14 NPT, M20  $\times$  1.5 (CM20), PG 13.5, or G  $\frac{1}{2}$  female (PF  $\frac{1}{2}$  female) conduit entry

### Process Connection

$\frac{1}{2}$ –14 NPT female, DIN 16288 G  $\frac{1}{2}$  male, RC  $\frac{1}{2}$  female (PT  $\frac{1}{2}$  female), M20  $\times$  1.5 (CM20) male

### Process Wetted Parts

#### Isolating Diaphragm

316L stainless steel or Hastelloy C-276

#### Process Connector

316L stainless steel CF-3M (Cast version of 316L SST, material per ASTM\_A743) or Hastelloy C-276

### Non-wetted Parts

#### Electronics Housing

Low-copper aluminum, NEMA 4X, IP65, IP67, CSA enclosure Type 4X

#### Paint

Polyurethane

#### Cover O-rings

Buna-N

#### Fill Fluid

Silicone or inert fill

#### Weight

Output Code S and N: Approximately 2.44 lb (1.11 kg)

## Tagging

The transmitter is tagged, at no charge, in accordance with customer requirements. All tags are stainless steel. The standard tag is permanently attached to the transmitter. Tag character height is  $\frac{1}{8}$  in. (0.318 cm). A wired tag is available upon request.

## Accessory Block and Bleed Valve (S5 Option)

The Rosemount 306 Integral Manifold is pre-assembled to transmitter and leak checked.

## Product Certifications

### Approved Manufacturing Locations

Rosemount Inc. — Chanhassen, Minnesota, USA  
 Emerson Process Management GmbH & Co. — Wessling, Germany  
 Emerson Process Management Asia Pacific Private Limited — Singapore  
 Beijing Rosemount Far East Instrument Co., LTD — Beijing, China

### European Union Directive Information

The EC declaration of conformity for all applicable European directives for this product can be found at [www.rosemount.com](http://www.rosemount.com). A hard copy may be obtained by contacting our local sales office.

#### ATEX Directive (94/9/EC)

Emerson Process Management complies with the ATEX Directive.

#### European Pressure Equipment Directive (PED) (97/23/EC)

2088/2090 Pressure Transmitters  
 — Sound Engineering Practice

#### Electro Magnetic Compatibility (EMC) (89/336/EEC)

All 2088/2090 Smart Pressure Transmitter:  
 EN 50081-1: 1992; EN 50082-2:1995; EN 61326-1:1997

#### Ordinary Location Certification for Factory Mutual

As standard, the transmitter has been examined and tested to determine that the design meets basic electrical, mechanical, and fire protection requirements by FM, a nationally recognized testing laboratory (NRTL) as accredited by the Federal Occupational Safety and Health Administration (OSHA).

### Hazardous Locations Certifications

#### North American Certifications

##### Factory Mutual (FM) Approvals

- E5** Explosion-Proof for Class I, Division 1, Groups B, C, and D. Dust-Ignition-Proof for Class II, Division 1, Groups E, F, G, Class III, Division 1, indoor and outdoor (NEMA 4X) hazardous locations; factory sealed.
- I5** Intrinsically safe for use in Class I, Division 1, Groups A, B, C, D; Class II, Division 1, Groups E, F, and G; and Class III, Division 1 when connected in accordance with Rosemount drawing 02088-1018. Non-incendive for Class I, Division 2, Groups A, B, C, and D.  
 For input parameters see control drawing 02088-1018.

#### Canadian Standards Association (CSA)

- C6** Explosion-Proof for Class I, Division 1, Groups B, C, and D. Dust-Ignition-Proof for Class II, Division 1, Groups E, F, G, Class III, indoor and outdoor hazardous locations. CSA enclosure Type 4X; factory sealed. Suitable for Class I, Division 2, Groups A, B, C, and D.  
 Intrinsically Safe for Class I, Division 1, Groups A, B, C, and D. Temp. Code T3C. Intrinsically safe when connected with approved barriers in accordance with Rosemount drawing 02088-1024.  
 For input parameters see control drawing 02088-1024.

### European Certifications



- I1** ATEX Intrinsically Safe  
 Certificate No.: BAS00ATEX1166X  II 1 G  
 EEx ia IIC T5 (T<sub>amb</sub> = -55 to 40 °C)  
 EEx ia IIC T4 (T<sub>amb</sub> = -55 to 70 °C)  
 CE 1180

TABLE 1. Input Parameters

Loop/Power	Input Type
U <sub>i</sub> = 30 V dc	Smart
I <sub>i</sub> = 200 mA	Smart
P <sub>i</sub> = 0.9 W	Smart
C <sub>i</sub> = 0.012 μF	Smart

#### Special Conditions for Safe Use (x):

When the optional transient protection terminal block is installed, the apparatus is not capable of withstanding a 500V rms test to case. This must be taken into account on any installation in which it is used, for example by assuring that the supply to the apparatus is galvanically isolated.

- N1** ATEX Type n  
 Certification No.: BAS00ATEX3167X  II 3 G  
 EEx nL IIC T5 (T<sub>a</sub> = -40 °C to 70 °C)  
 U<sub>i</sub> = 50 V dc max  
 CE

#### Special Conditions for Safe Use (x):

When the optional transient protection terminal block is installed, the apparatus is not capable of withstanding a 500 V r.m.s. test to case. This must be taken into account on any installation in which it is used, for example, by assuring that the supply to the apparatus is galvanically isolated.

# Rosemount 2088

**ND** ATEX Combustible Dust

Certificate No.: BAS01ATEX1427X  II 1 D

T105°C (T<sub>amb</sub> = -20°C to 85°C)

IP66

**CE** 1180

V<sub>max</sub> = 36 V dc Max

I<sub>i</sub> = 24 mA

**Special Conditions for Safe Use (x):**

1. The user must ensure that the maximum rated voltage and current (36 volts, 24 mA, D.C.) are not exceeded. All connections to other apparatus or associated apparatus shall have control over this voltage and current equivalent to a category "ib" circuit according to EN50020.
2. Cable entries must be used which maintain the ingress protection of the enclosure to at least IP66.
3. Unused cable entries must be filled with suitable blanking plugs which maintain the ingress protection of the enclosure to at least IP66.
4. Cable entries and blanking plugs must be suitable for the ambient range of the apparatus and capable of withstanding a 7J impact test.
5. The 2088/2090 sensor module must be securely screwed in place to maintain the ingress protection of the enclosure.

**ED** ATEX Flame-Proof

Certification No.: KEMA97ATEX2378  II 1/2 G

EEx d IIC T6 (T<sub>a</sub> = -20 °C to 40°C)

T4 (T<sub>a</sub> = -20 °C to 80 °C)

**CE** 1180

V<sub>max</sub> = 36 (with Smart output option)

V<sub>max</sub> = 14 (with low power output option)

**Japanese Certifications**

**E4** JIS Flame-Proof

Ex d IIC T6 (T<sub>amb</sub> = 85 °C)

Certificate	Description
C15879	2088 Smart with SST wetted parts (with meter)
C15877	2088 Smart with Hast wetted parts (with meter)
C15876	2088 Smart with Hast wetted parts (no meter)
C15875	2088 Smart with SST wetted parts (no meter)
C15874	2088 Smart with Hast wetted parts, CR Option (with meter)
C15873	2088 Smart with Hast wetted parts, CR Option (no meter)
C15872	2088 Smart with SST wetted parts, CR Option (with meter)
C15871	2088 Smart with SST wetted parts, CR Option (no meter)

**Combinations of Certifications**

Stainless steel certification tag is provided when optional approval is specified. Once a device labeled with multiple approval types is installed, it should not be reinstalled using any other approval types. Permanently mark the approval label to distinguish it from unused approval types.

**KB** Combination of E5, I5, and C6

**KH** Combination of E5, I5, and I1

**K5** Combination of E5 and I5

**K6** Combination of C6, I1, and ED

**Dimensional Drawings**

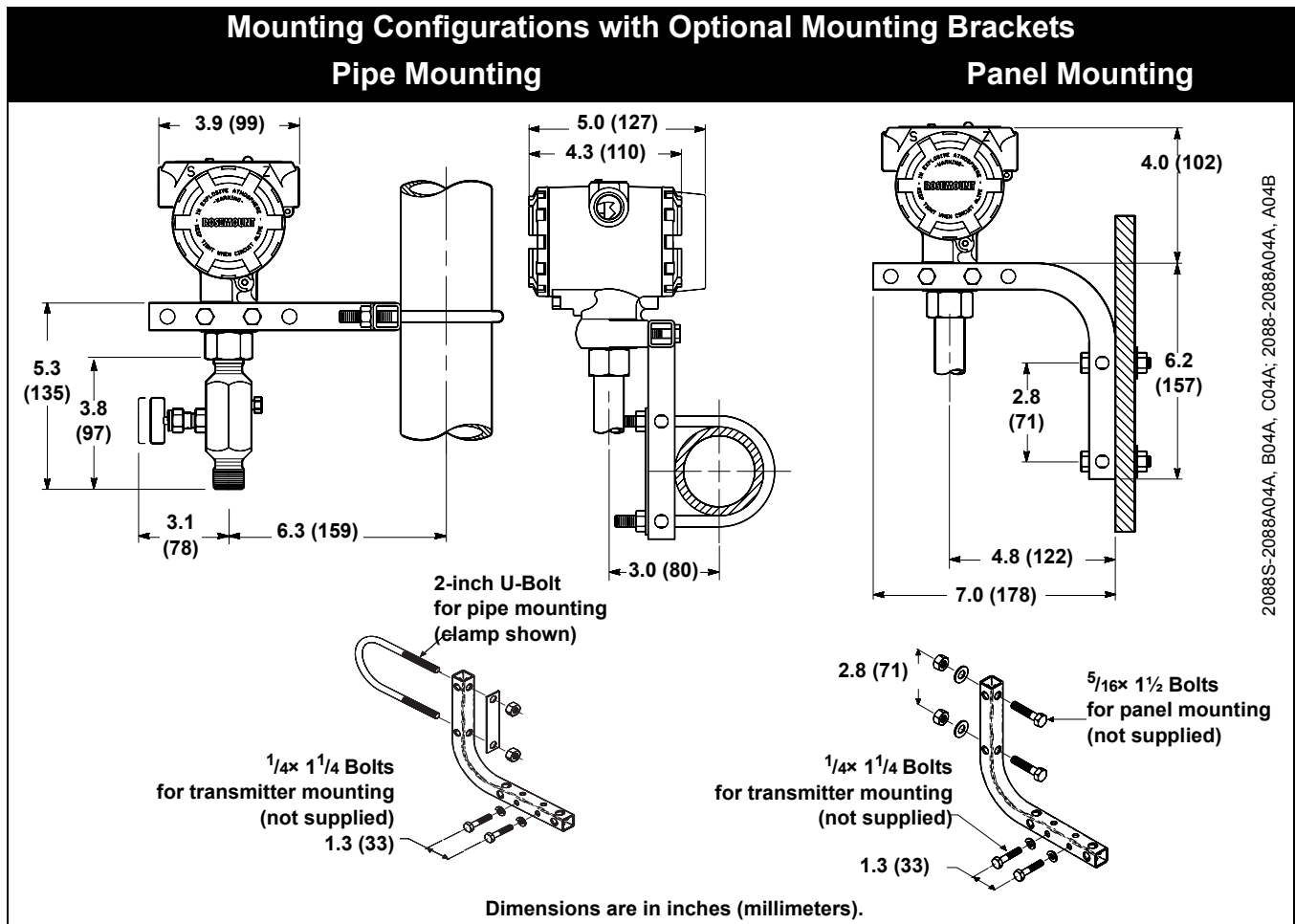
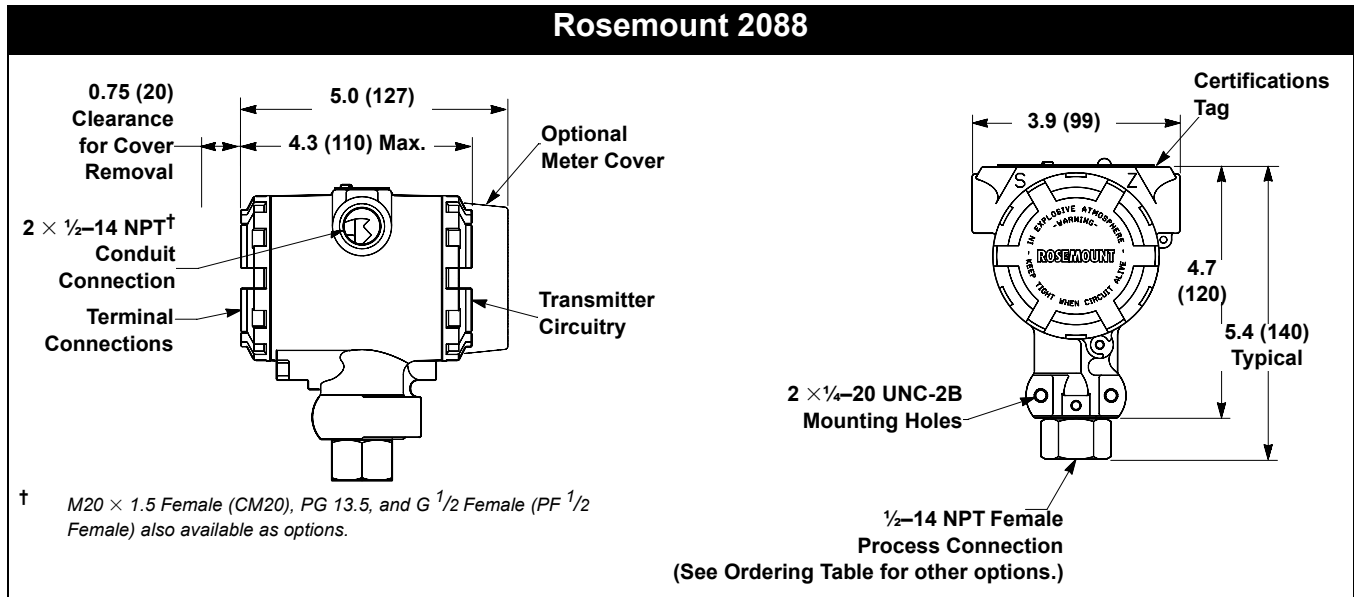

## Ordering Information

Model	Product description		
2088	Pressure Transmitter		
Code	Transmitter type		
A	Absolute		
G	Gage		
Code	Range	Minimum span	URL/Max.span/Sensor limit
1	0–30 psi (0–2.1 bar)	1.5 psi (103.0 mbar)	30 psi (2.1 bar)
2	0–150 psi (0–10.3 bar)	7.5 psi (517.0 mbar)	150 psi (10.3 bar)
3	0–800 psi (0–55.2 bar)	40 psi (2.8 bar)	800 psi (55.2 bar)
4	0–4,000 psi (0–275.8 bar)	200 psi (13.8 bar)	4000 psi (275.8 bar)
Code	Output		
S	4–20 mA dc/Digital HART <sup>®</sup> Protocol		
N	1-5 V dc Low Power/ Digital HART protocol		
Materials of Construction			
Code	Process connection	Isolating diaphragm	Oil fill
22 <sup>(1)</sup>	316L SST	316L SST	Silicone
33 <sup>(1)</sup>	Hastelloy C-276	Hastelloy C-276	Silicone
2B <sup>(1)</sup>	316L SST	316L SST	Inert
Code	Process connection		
A	½–14 NPT Female		
B	DIN 16288 G ½ Male		
C <sup>(2)</sup>	RC ½ Female (PT ½ Female)		
D <sup>(2)</sup>	M20 × 1.5 Male (CM20 Male)		
Code	Conduit thread		
1	½–14 NPT		
2	M20 × 1.5 Female (CM20)		
3	PG 13.5		
4	G ½ Female (PF ½ Female)		
Code	Options		
<b>Integral manifold</b>			
S5	Assembly to Rosemount 306 integral manifold (Use ½ - 14 NPT Female Process Connection code A)		
<b>Diaphragm seal assemblies</b>			
S1	Attachment of one diaphragm seal		
<b>Mounting brackets</b>			
B4	SST mounting bracket with SST Bolts		
<b>Special configuration (software)</b>			
C4 <sup>(4)</sup>	NAMUR alarm and saturation levels, high alarm		
CN <sup>(4)</sup>	NAMUR alarm and saturation levels, low alarm		
C9 <sup>(3)</sup>	Software configuration		
<b>Special configuration (hardware)</b>			
C2	0.8 - 3.2 V dc output with HART protocol, Output code N only.		
CR	Compound range calibration capability		

## Product Data Sheet

00813-0100-4690, Rev GA

August 2004

# Rosemount 2088

### Product Certifications

I1 <sup>(4)</sup>	ATEX Intrinsically Safe
N1 <sup>(4)</sup>	ATEX Type n
ND <sup>(4)</sup>	ATEX Combustible Dust
ED	ATEX Flame-Proof
C6	CSA Explosion-Proof, Intrinsically Safe, and non-Incendive
K6 <sup>(4)</sup>	CSA and ATEX Explosion-proof and Intrinsically Safe (combination of C6, I1, and ED)
E4 <sup>(4)</sup>	JIS Flameproof (Available with Conduit Thread code 4 and with or without Digital Display codes M5 and M7)
E5	FM Approvals explosion-proof
I5	FM Approvals Intrinsically safe, non-incendive
K5	FM Approvals Explosion-proof, Intrinsically Safe, non-incendive (combination of E5 and I5)
KB	FM Approvals and CSA Explosion-proof, Intrinsically Safe, non-incendive (combination of E5, I5, and C6)
KH <sup>(4)</sup>	FM Approvals and ATEX Explosion-Proof and Intrinsically Safe (combination of E5, I5, and I1)
DW	NSF drinking water approval (Requires Materials of Construction code 22 with Process Connection code A.)

### Digital Display

M5	LCD display, scaled 0–100%
M7	LCD display, special configuration

### Special procedures

P1	Hydrostatic testing
P2	Cleaning for special service
P8 <sup>(5)</sup>	0.075% accuracy to 10:1 turndown

### Special certifications

Q4	Calibration certificate
Q16	Surface finish certification for sanitary remote seals

### Terminal blocks

T1	Transient protection (Available with Option codes E5, ED, I1, I5, N1, C6, and K5.
----	---

- (1) *Materials of Construction comply with recommendations per NACE MR0175/ISO 15156 for sour oil field production environments. Environmental limits apply to certain materials. Consult latest standard for details. Selected materials also conform to NACE MR0103 for sour refining environments.*
- (2) *Not available with Hastelloy C-276, Materials of Construction code 33.*
- (3) *A Configuration Data Sheet, see page 10, must be completed.*
- (4) *Not available with low-power Output code N.*
- (5) *Available with Output code S, stainless steel isolators, silicone fill, and for spans of 10 inH<sub>2</sub>O and greater.*





## Product Data Sheet

00813-0100-4690, Rev GA

August 2004

# Rosemount 2088

---

*Rosemount, the Rosemount logotype, Annubar, ProPlate and Mass ProPlate are registered trademarks of Rosemount Inc.  
HART is a registered trademark of the HART Communications Foundation.  
Hastelloy and Hastelloy C-276 are registered trademarks of Haynes International.  
PlantWeb is a registered trademark of one of the Emerson Process Management group of companies.  
All other marks are the property of their respective owners.*

### Emerson Process Management

#### Rosemount Inc.

8200 Market Boulevard  
Chanhassen, MN 55317 USA  
T (U.S.) 1 800 999 9307  
T (International) (952) 906 8888  
F (952) 949 7001

[www.rosemount.com](http://www.rosemount.com)

#### Emerson Process Management GmbH & Co.

Argelsrieder Feld 3  
82234 Wessling  
Germany  
T 49 (8153) 9390  
F 49 (8153) 939172

#### Emerson Process Management Asia Pacific Private Limited

1 Pandan Crescent  
Singapore 128461  
T (65) 6777 8211  
F (65) 6777 0947  
[AP.RMT-Specialist@emersonprocess.com](mailto:AP.RMT-Specialist@emersonprocess.com)

