

Product Data Sheet

00813-0100-4003, Rev MB
August 2004

Rosemount 8800C

Rosemount 8800C Vortex Flowmeter

**HART® AND FOUNDATION™
FIELD BUS PROTOCOLS**

- Available in wafer, flanged, dual, and reducer designs.
- Only manufacturer of Reducer™ Vortex which extends the measurable flow range, reduces installation costs, and minimizes project risk.
- All-welded, non-clog design eliminates ports and gaskets.
- Patented Adaptive Digital Signal Process (ADSP) provides vibration immunity.
- Unique isolated sensor design allows replacement without breaking the process seal.
- Simplified troubleshooting through device diagnostics.

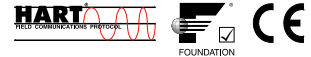

Content

Specifications page 5

Product Certificates page 18

Dimensional Drawings page 21

Ordering Information page 35

Configuration Data Sheet page 38

ROSEMOUNT®

www.rosemount.com



EMERSON™
Process Management

THE ROSEMOUNT 8800C DELIVERS RELIABILITY

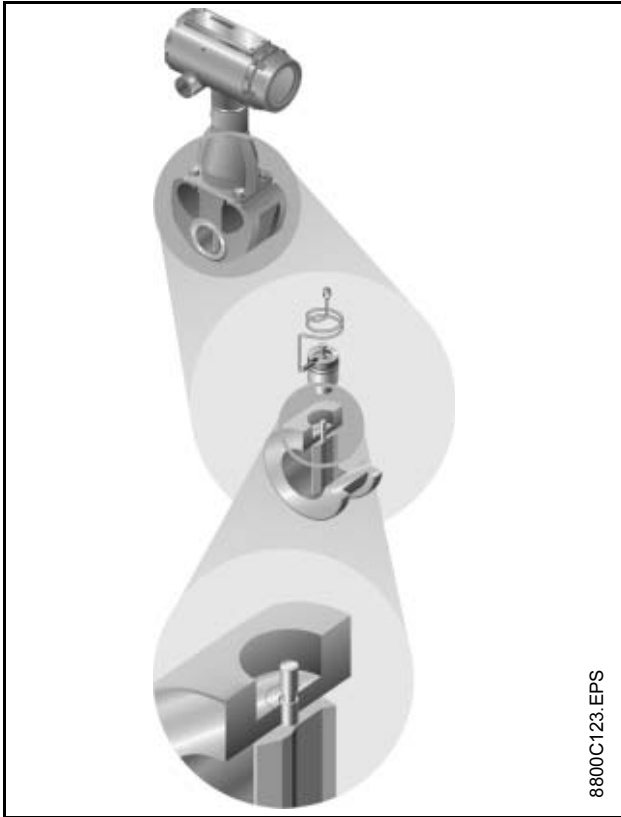

- **Rosemount Reliability** -The 8800C Vortex eliminates impulse lines, ports, and gaskets to improve reliability.
- **Non-clog Design** - Unique gasket-free construction which has no ports that can clog.
- **Vibration Immunity** - Mass Balancing of the sensor system, and Patented Adaptive Digital Signal Processing (ADSP) provide Vibration immunity.
- **Replaceable Sensor** - The sensor is isolated from the process and can be replaced without breaking the process seals. All line sizes uses same sensor design allowing a single spare to serve every meter.
- **Simplified Troubleshooting** - Device Diagnostics enable field verification of Meter Electronics and Sensor with no process shutdown.

THE ROSEMOUNT 8800C OFFERING

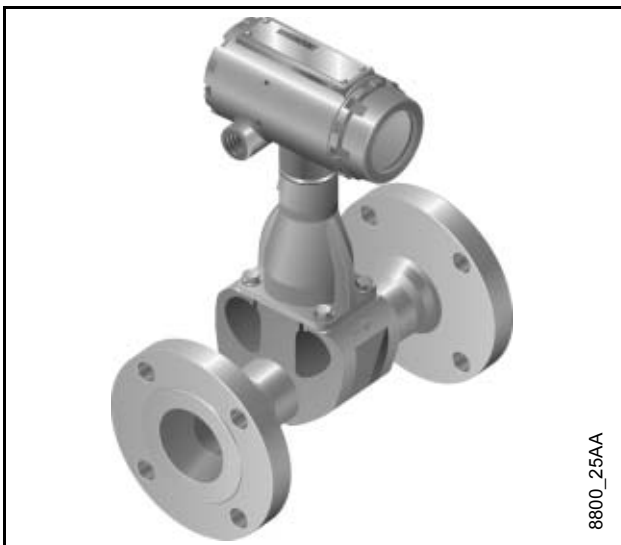

- The 8800C is available in wafer style meter bodies for 1/2 through 8 inch line sizes, and ASME B16.5 (ANSI), DIN, or JIS flanged style meter bodies for 1/2 through 12 inch line sizes.
- Alignment rings, provided with each wafer-style flowmeter, ensure that the meter body is properly centered with the adjacent piping.
- Both wafer and flanged style meter bodies are available in 316L and Hastelloy C materials of construction.
- Available up to ANSI class 1500 for 1 through 12 inch (25 mm through 100 mm) and ANSI class 900 for 1/2 inch (15 mm).
- Available with FOUNDATION fieldbus functionality which includes Device Diagnostics and PlantWeb Alerts.



THE ROSEMOUNT 8800CR REDUCER™ VORTEX EXTENDS THE MEASURABLE FLOW RANGE AT A REDUCED COST

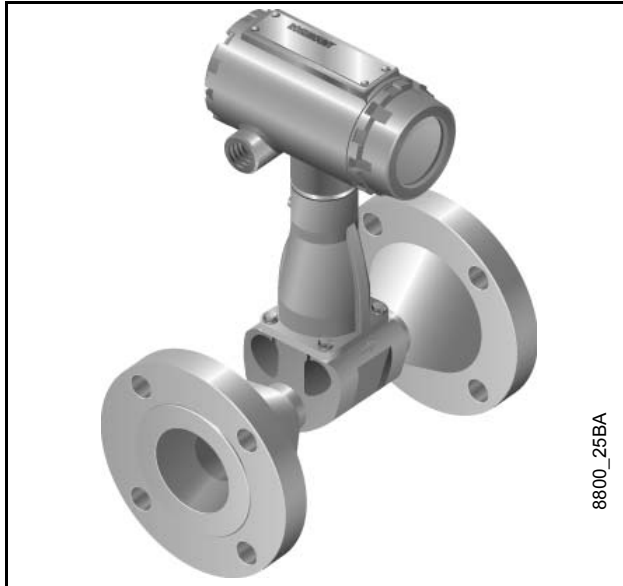

- **Rosemount Reliability** - Designed with same electronics, sensor, and meter body as the 8800C.
- **Reduced Cost** - Eliminates field assembly and welding of separate reducers and piping reducing installed cost by as much as 50%.
- **Extended Measurable Flow** - Low-end flow range is doubled with the Rosemount 8800CR Reducer Vortex.
- **Reduced Project Risk** - Reducer Vortex and the Standard Vortex have the same face-to-face dimension. As a result either meter can be used without affecting pipe layout.
- Available as flanged meter for 1 through 12 inch stainless steel and *Hastelloy C* materials of construction.
- Available with FOUNDATION fieldbus functionality.

THE DUAL-SENSOR VORTEX FLOWMETER

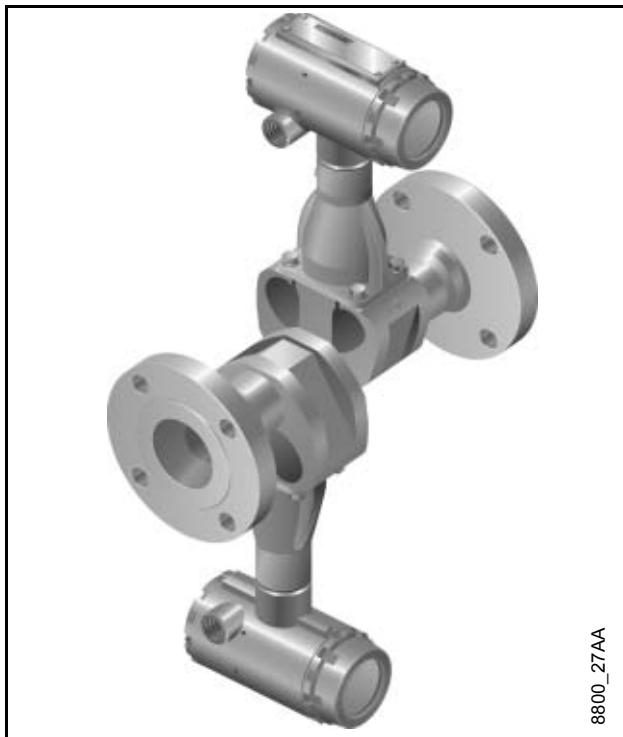

- **Safety Integrated Systems (SIS)** - Ideal solution where redundant flow signals are required.
- **Rosemount Reliability** - Designed with same electronics, sensor, and meter body as the 8800C.
- **Redundant Flow Measurement** - Dual Vortex meter is constructed of two complete vortex meters: sensor, electronics, and shedder bar⁽¹⁾. The meters are welded together and flow calibrated to provide an accurate single flowmeter with two independent flow measurements.
- Available as flanged meter for 1/2 through 12 inch stainless steel and *Hastelloy C* materials of construction.

(1) 10 and 12 inch (250mm and 300mm) Dual Design has a single shedder bar.

Rosemount 8800C

ROSEMOUNT 8800C VORTEX FLOWMETER WITH FOUNDATION FIELDBUS

The software for the 8800C Flowmeter with FOUNDATION fieldbus permits remote testing and configuration using any FOUNDATION fieldbus-compliant host, such as the DeltaV system from Emerson Process Management.

Transducer Block

The transducer block calculates flow from sensor frequency. The calculation includes information about damping, shedding frequency, K-factor, service type, pipe ID, and diagnostics.

Resource Block

The resource block contains physical transmitter information, including available memory, manufacturer identification, device type, software tag, and unique identification.

Backup Link Active Scheduler (LAS)

The transmitter is classified as a device link master. A device link master can function as a Link Active Scheduler (LAS) if the current link master device fails or is removed from the segment.

The host or other configuration tool is used to download the schedule for the application to the link master device. In the absence of a primary link master, the transmitter will claim the LAS and provide permanent control for the H1 segment.

Diagnostics

The transmitter automatically performs continuous self-diagnostics. The user can perform on-line testing of the transmitter digital signal. Advanced simulation diagnostics are available. This enables remote verification of the electronics via a flow signal generator built into the software. The sensor strength value can be used to view the process flow signal and provide optimized filter settings.

FOUNDATION Fieldbus Function Blocks

Analog Input

The AI function block processes the measurement and makes it available to other function blocks. The AI function block also allows filtering, alarming, and engineering unit changes.

The 8800C Flowmeter with FOUNDATION fieldbus comes standard with one AI function block.

Proportional/Integral/Derivative

The optional PID function block provides a sophisticated implementation of the universal PID algorithm. The PID function block features input for feed forward control, alarms on the process variable, and control deviation. The PID type (series or Instrument Society of America [ISA]) is user-selectable on the derivative filter.

Setup

Basic setup requires connecting the transmitter to a fieldbus network. The FOUNDATION fieldbus-compliant host will automatically establish communication with the device.

The Rosemount 8800C Flowmeter can be easily configured using the DeltaV system.

User-configurable parameters include: tag, range values and units, service type, damping, process density, pipe internal diameter (ID)⁽¹⁾, and process temperature⁽¹⁾

Tagging information can be entered into the transmitter to allow identification and a physical description. 32-character tags are provided for identification of the transmitter and each function block.

(1) Process temperature and pipe ID have known effects on the K-factor. The 8800C software automatically accounts for these effects by compensating the K-factor.

Specifications

The following specifications are for the Rosemount 8800C, Rosemount 8800CR, and Rosemount 8800CD, except where noted.

FUNCTIONAL SPECIFICATIONS

Service

Liquid, gas, and steam applications. Fluids must be homogeneous and single-phase.

Line Sizes

Wafer

1/2, 1, 1 1/2, 2, 3, 4, 6, and 8 inches
(DN 15, 25, 40, 50, 80, 100, 150, and 200)

Flanged and Dual-Sensor Style

1/2, 1, 1 1/2, 2, 3, 4, 6, 8, 10, and 12 inches
(DN 15, 25, 40, 50, 80, 100, 150, 200, 250, and 300)

Reducer

1, 1 1/2, 2, 3, 4, 6, 8, 10, and 12 inches
(DN 25, 40, 50, 80, 100, 150, 200, 250, and 300)

Pipe Schedules

Process piping Schedules 10, 40, and 80

NOTE

The appropriate bore diameter of the process piping must be entered using the HART Communicator or AMS. Meters will be shipped from the factory at the Schedule 40 default value unless otherwise specified.

Measurable Flow Rates

Capable of processing signals from flow applications which meet the sizing requirements below.

To determine the appropriate flowmeter size for an application, process conditions must be within the Reynolds number and velocity limitations for the desired line size provided in Table 1, Table 2, Table 3, and Table 4.

NOTE

Consult your local sales representative to obtain a computer sizing program that describes in greater detail how to specify the correct flowmeter size for an application.

The Reynolds number equation shown below combines the effects of density (ρ), viscosity (μ_{cp}), pipe inside diameter (D), and flow velocity (V).

$$R_D = \frac{VD\rho}{\mu_{cp}}$$

TABLE 1. Minimum Measurable Meter Reynolds Numbers

Meter Sizes (Inches / DN)	Reynolds Number Limitations
1/2 through 4/15	10000 minimum
6 through 12 / 150 through 300	20000 minimum

TABLE 2. Minimum Measurable Meter Velocities
(Use the larger of the two values)

	Feet per Second	Meters per Second
Liquids ⁽¹⁾	$\sqrt{36/\rho}$ or 0.7	$\sqrt{54/\rho}$ or 0.22
Gases	$\sqrt{36/\rho}$ or 6.5	$\sqrt{54/\rho}$ or 2.0

The ρ is the process fluid density at flowing conditions in lb/ft³ for ft/s and kg/m³ for m/s

(1) The minimum measurable velocity for the 10in. line size is 0.94 ft/s (.27m/s) and 1.11 ft/s (.34m/s) for the 12in. line size.

TABLE 3. Maximum Measurable Meter Velocities
(Use the smaller of the two values)

	Feet per Second	Meters per Second
Liquids	$\sqrt{90,000/\rho}$ or 25	$\sqrt{134,000/\rho}$ or 7.6
Gases ⁽¹⁾	$\sqrt{90,000/\rho}$ or 25C	$\sqrt{134,000/\rho}$ or 76

The ρ is the process fluid density at flowing conditions in lb/ft³ for ft/s and kg/m³ for m/s

(1) Accuracy limitations for gas and steam for Dual-style meters (all sizes): max velocity of 100 ft/s (30.5 m/s).

Process Temperature Limits

Standard

-40 to 450 °F (-40 to 232 °C)

Extended

-330 to 800 °F (-200 to 427 °C)

Output Signals

4–20 mA Digital HART Signal

Superimposed on 4–20 mA signal

Optional Scalable Pulse Output

0 to 10000 Hz; transistor switch closure with adjustable scaling via HART communications; capable of switching up to 30 V dc, 120 mA maximum

Digital Foundation fieldbus signal

Manchester-encoded digital signal that conforms to IEC 1158-2 and ISA 50.02.

Analog Output Adjustment

Engineering units and lower and upper range values are user-selected. Output is automatically scaled to provide 4 mA at the selected lower range value, 20 mA at the selected upper range value. No frequency input is required to adjust the range values.

Scalable Frequency Adjustment

Value of one pulse can be set to equal desired volume in selected engineering units.

Ambient Temperature Limits

Operating

–58 to 185 °F (–50 to 85 °C)

–4 to 185 °F (–20 to 85 °C) for flowmeters with local indicator

Storage

–58 to 250 °F (–50 to 121 °C)

–50 to 185 °F (–46 to 85 °C) for flowmeters with local indicator

Pressure Limits

Flange Style Meter

Rated for ASME B16.5 (ANSI) Class 150, 300, 600, 900, and 1500, DIN PN 10, 16, 25, 40, 64, 100, and 160, and JIS 10K, 20K, and 40K

Reducer Style Meter

Rated for ASME B16.5 (ANSI) Class 150, 300, 600, and 900, DIN PN 10, 16, 25, 40, 64, 100, and 160, and JIS 10K, 20K, and 40K

Dual Sensor Style Meter

Rated for ASME B16.5 (ANSI) Class 150, 300, 600, and 900, DIN PN 10, 16, 25, 40, 64, 100, and 160, and JIS 10K, 20K, and 40K

Wafer Style Meter

Rated for ASME B16.5 (ANSI) Class 150, 300, and 600, DIN PN 10, 16, 25, 40, 64, and 100, and JIS 10K, 20K, and 40K

Power Supply

HART Analog

External power supply required. Flowmeter operates on 10.8 to 42 V dc terminal voltage (with 250-ohm minimum load required for HART communications, 16.8 V dc power supply is required)

Foundation fieldbus

External power supply required. Flowmeter operates on 9 to 32 V dc, 17.8 mA nominal, 19.0 mA maximum.

Power Consumption

One watt maximum

Load Limitations (HART Analog)

Maximum loop resistance is determined by the voltage level of the external power supply, as described by:

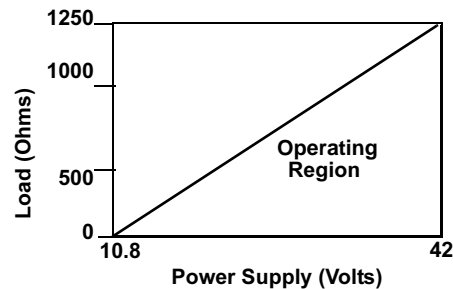

$$R_{\max} = 41.7(V_{ps} - 10.8)$$

$$V_{ps} = \text{Power Supply Voltage (Volts)}$$

$$R_{\max} = \text{Maximum Loop Resistance (Ohms)}$$

NOTE

HART Communication requires a minimum loop resistance of 250 ohms.

Optional LCD Indicator

Displays flow variable, percent of range, current output, and/or totalized flow.

Enclosure Rating

NEMA Type 4X; CSA Type 4X; IP66

Permanent Pressure Loss

The approximate permanent pressure loss (PPL) from the Rosemount 8800C flowmeter is calculated for each application in the free Vortex sizing software available at Rosemount.com. The PPL is determined using the equation:

$$PPL = \frac{A \times \rho_f \times Q^2}{D^4}$$

where:

- PPL = Permanent Pressure loss (psi or kPa)
- where:
- ρ_f = Density at operating conditions (lb/ft³ or kg/m³)
- Q = Actual volumetric flow rate (Gas = ft³/min or m³/hr; Liquid = gal/min or l/min)
- D = Flowmeter bore diameter (in. or mm)
- A = Constant depending on meter style, fluid type and flow units. Determined per following table:

TABLE 4. Determining the PPL

Meter Style	English Units		SI Units	
	A _{Liquid}	A _{Gas}	A _{Liquid}	A _{Gas}
8800CF/W	3.4 × 10 ⁻⁵	1.9 × 10 ⁻³	0.425	118
8800CR	3.91 × 10 ⁻⁵	2.19 × 10 ⁻³	0.489	136
8800CD ⁽¹⁾	6.12 × 10 ⁻⁵	3.42 × 10 ⁻³	0.765	212

(1) For 10 and 12 in (250 and 300 mm) line sizes, A for Rosemount 8800CD is the same as Rosemount 8800CF.

Minimum Back Pressure (Liquids)

Flow metering conditions that would allow cavitation, the release of vapor from a liquid, should be avoided. This flow condition can be avoided by remaining within the proper flow range of the meter and by following appropriate system design.

For some liquid applications, incorporation of a back pressure valve should be considered. To prevent cavitation, the minimum back pressure should be:

$$P = 2.9\Delta P + 1.3 p_v$$

P = Line pressure five pipe diameters downstream of the meter (psia or kPa abs)

ΔP = Pressure loss across the meter (psi or kPa)

p_v = Liquid vapor pressure at operating conditions (psia or kPa abs)

Failure Mode Alarm

HART Analog

If self-diagnostics detect a gross flowmeter failure, the analog signal will be driven either below 3.75 mA or above 21.75 mA to alert the user. Also, high or low alarm signal is user-selectable through the fail mode alarm jumper on the electronics.

NAMUR-compliant alarm limits are available through the C4 or CN Option. NAMUR-compliant limits are 3.6 mA (low) or 22.5 mA (high).

Foundation fieldbus

The AU block allows to the user to configure the alarm to HI-HI, HI, LO, or LO-LO with a variety of priority levels.

Saturation Output Values

When the operating flow is outside the range points, the analog output continues to track the operating flow until reaching the saturation value listed below; the output does not exceed the listed saturation value regardless of the operating flow.

The 4–20 mA Saturation Values are 3.9 mA (low) or 20.8 mA (high). The NAMUR-Compliant Saturation Values (Option C4 or CN) are 3.8 mA (low) or 20.5 mA (high).

Damping

Adjustable between 0.2 and 255 seconds

Response Time

Three vortex shedding cycles or 0.2 seconds, whichever is greater, maximum required to reach 63.2% of actual input with the minimum damping (0.2 seconds).

Turn-on Time

HART Analog

Less than four (4) seconds plus the response time to rated accuracy from power up.

Foundation fieldbus

Performance within specifications no greater than 10.0 seconds after power is applied.

Transient Protection

The optional transient terminal block prevents damage to the flowmeter from transients induced by lightning, welding, heavy electrical equipment, or switch gears. The transient protection electronics are located in the terminal block.

The transient terminal block meets the following specifications:

- ASME B16.5 (ANSI)/IEEE C62.41 - 1980 (IEEE 587) Categories A, B
- 3 kA crest (8 × 20 μs)
- 6 kV crest (1.2 × 50 μs)
- 6 kV/0.5 kA (0.5 μs, 100 kHz, ring wave)

Security Lockout

When the security lockout jumper is enabled, the electronics will not allow you to modify functions that affect flowmeter output.

Rosemount 8800C

Output Testing

Current Source

Flowmeter may be commanded to set the current to a specified value between 4 and 20 mA.

Frequency Source

Flowmeter may be commanded to set the frequency to a specified value between 0 and 10000 Hz.

Low Flow Cutoff

Adjustable over entire flow range. Below selected value, output is driven to 4 mA and zero pulse output frequency (in the scaled pulse mode only).

Humidity Limits

Operates in 0–95% relative humidity under noncondensing conditions (tested to IEC 770, Section 6.2.11).

Overrange Capability

HART Analog

Analog signal output continues to 105 percent of span, then remains constant with increasing flow. The digital and pulse outputs will continue to indicate flow up to the upper sensor limit of the flowmeter and a maximum frequency of 10400 Hz.

Foundation fieldbus

For liquid service type, the transducer block digital output will continue to a nominal value of 25 ft/s. After that, the status associated with the transducer block output will go to UNCERTAIN. Above a nominal value of 30 ft/s, the status will go to BAD.

For gas/steam service, the transducer block digital output will continue to a nominal value of 220 ft/s for 0.5 and 1.0 in. line sizes and a nominal value of 250 ft/s for 1.5–8 in. line sizes. After that, the status associated with the transducer block output will go to UNCERTAIN. Above a nominal value of 300 ft/s for all line sizes, the status will go to BAD.

Flow Calibration

Meter bodies are flow-calibrated and assigned a unique calibration factor (K-factor) at the factory. The calibration factor is entered into the electronics, enabling interchangeability of electronics and/or meter bodies without calculations or compromise in accuracy.

Status (FOUNDATION fieldbus only)

If self-diagnostics detect a transmitter failure, the status of the measurement will inform the control system. Status may also send the PID output to a safe value.

Schedule Entries (FOUNDATION fieldbus only)

Six (6)

Links (FOUNDATION fieldbus only)

Twelve (12)

Virtual Communications Relationships (VCRs) (FOUNDATION fieldbus only)

Two (2) predefined (F6, F7)

Four (4) configured (see Table 5)

TABLE 5. Block Information.

Block	Base Index	Execution Time (Milliseconds)
Resource (RB)	300	—
Transducer (TB)	400	—
Analog Input (AI)	1,000	15
Proportional/Integral/Derivative (PID)	10,000	25

TABLE 6. Typical pipe velocity ranges for 8800C and 8800CR⁽¹⁾

Process Line Size (Inches/ DN)	Vortex Meter ⁽²⁾	Liquid Velocity Ranges		Gas Velocity Ranges	
		(ft/s)	(m/s)	(ft/s)	(m/s)
0.5/ 15	8800CF005	0.70 to 25.0	0.21 to 7.6	6.50 to 250.0	1.98 to 76.2
1/ 25	8800CF010	0.70 to 25.0	0.21 to 7.6	6.50 to 250.0	1.98 to 76.2
	8800CR010	0.25 to 8.8	0.08 to 2.7	2.29 to 87.9	0.70 to 26.8
1.5/ 40	8800CF015	0.70 to 25.0	0.21 to 7.6	6.50 to 250.0	1.98 to 76.2
	8800CR015	0.30 to 10.6	0.09 to 3.2	2.76 to 106.1	0.84 to 32.3
2/ 50	8800CF020	0.70 to 25.0	0.21 to 7.6	6.50 to 250.0	1.98 to 76.2
	8800CR020	0.42 to 15.2	0.13 to 4.6	3.94 to 151.7	1.20 to 46.2
3/ 80	8800CF030	0.70 to 25.0	0.21 to 7.6	6.50 to 250.0	1.98 to 76.2
	8800CR030	0.32 to 11.3	0.10 to 3.5	2.95 to 113.5	0.90 to 34.6
4/ 100	8800CF040	0.70 to 25.0	0.21 to 7.6	6.50 to 250.0	1.98 to 76.2
	8800CR040	0.41 to 14.5	0.12 to 4.4	3.77 to 145.2	1.15 to 44.3
6/ 150	8800CF060	0.70 to 25.0	0.21 to 7.6	6.50 to 250.0	1.98 to 76.2
	8800CR060	0.31 to 11.0	0.09 to 3.4	2.86 to 110.2	0.87 to 33.6
8/ 200	8800CF080	0.70 to 25.0	0.21 to 7.6	6.50 to 250.0	1.98 to 76.2
	8800CR080	0.40 to 14.4	0.12 to 4.4	3.75 to 144.4	1.14 to 44.0
10/ 250	8800CF100	0.90 to 25.0	0.27 to 7.6	6.50 to 250.0	1.98 to 76.2
	8800CR100	0.44 to 15.9	0.13 to 4.8	4.12 to 158.6	1.26 to 48.3
12/ 300	8800CF120	1.10 to 25.0	0.34 to 7.6	6.50 to 250.0	1.98 to 76.2
	8800CR120	0.63 to 17.6	0.19 to 5.4	4.58 to 176.1	1.40 to 53.7

(1) Table 6 is a reference of pipe velocities that can be measured for the standard Rosemount 8800C and the reducer Rosemount 8800CR Vortex Meters. It does not consider density limitations, as described in tables 2 and 3.

(2) Velocity range of the Rosemount 8800CW is the same as Rosemount 8800CF.

TABLE 7. Water Flow Rate Limits for the Rosemount 8800C and 8800CR⁽¹⁾

Process Line Size (Inches/ DN)	Vortex Meter ⁽²⁾	Minimum and Maximum Measurable Water Flow Rates*	
		Gallons/Minute	Cubic Meters/Hour
0.5/ 15	8800CF005	1.76 to 23.7	0.40 to 5.4
1/ 25	8800CF010	2.96 to 67.3	0.67 to 15.3
	8800CR010	1.76 to 23.7	0.40 to 5.4
1.5/ 40	8800CF015	4.83 to 158	1.10 to 35.9
	8800CR015	2.96 to 67.3	0.67 to 15.3
2/ 50	8800CF020	7.96 to 261	1.81 to 59.4
	8800CR020	4.83 to 158.0	1.10 to 35.9
3/ 80	8800CF030	17.5 to 576	4.00 to 130
	8800CR030	7.96 to 261.0	1.81 to 59.3
4/ 100	8800CF040	30.2 to 992	6.86 to 225
	8800CR040	17.5 to 576	4.00 to 130
6/ 150	8800CF060	68.5 to 2251	15.6 to 511
	8800CR060	30.2 to 992	6.86 to 225
8/ 200	8800CF080	119 to 3898	27.0 to 885
	8800CR080	68.5 to 2251	15.6 to 511
10/ 250	8800CF100	231 to 6144	52.2 to 1395
	8800CR100	119 to 3898	27.0 to 885
12/ 300	8800CF120	391 to 8813	88.8 to 2002
	8800CR120	231 to 6144	52.2 to 1395

***Conditions: 77 °F (25 °C) and 14.7 psia (1.01 bar absolute)**

(1) Table 7 is a reference of flow rates that can be measured for the standard Rosemount 8800C and the reducer 8800CR Vortex Meters. It does not consider density limitations, as described in tables 2 and 3.

(2) Velocity range of the 8800CW is the same as 8800CF.

TABLE 8. Air Flow Rate Limits at 59 °F (15 °C)

Process Pressure	Flow Rate Limits	Minimum and Maximum Air Flow Rates for line sizes 1/2 inch/DN 15 through 1 inch/DN 25							
		1/2 Inch/DN 15				1 Inch/DN 25			
		Rosemount 8800C		Rosemount 8800CR		Rosemount 8800C		Rosemount 8800CR	
		ACFM	ACMH	ACFM	ACMH	ACFM	ACMH	ACFM	ACMH
0 psig (0 bar G)	max	27.9	47.3	Not Available	Not Available	79.2	134	27.9	47.3
	min	3.86	6.56	Available	Available	7.81	13.3	3.86	6.56
50 psig (3,45 bar G)	max	27.9	47.3	Not Available	Not Available	79.2	134	27.9	47.3
	min	1.31	2.22	Available	Available	3.72	6.32	1.31	2.22
100 psig (6,89 bar G)	max	27.9	47.3	Not Available	Not Available	79.2	134	27.9	47.3
	min	0.98	1.66	Available	Available	2.80	4.75	0.98	1.66
150 psig (10,3 bar G)	max	27.9	47.3	Not Available	Not Available	79.2	134	27.9	47.3
	min	0.82	1.41	Available	Available	2.34	3.98	0.82	1.41
200 psig (13,8 bar G)	max	27.9	47.3	Not Available	Not Available	79.2	134	27.9	47.3
	min	0.82	1.41	Available	Available	2.34	3.98	0.82	1.41
300 psig (20,7 bar G)	max	27.9	47.3	Not Available	Not Available	79.2	134	27.9	47.3
	min	0.82	1.41	Available	Available	2.34	3.98	0.82	1.41
400 psig (27,6 bar G)	max	25.7	43.9	Not Available	Not Available	73.0	124	25.7	43.9
	min	0.82	1.41	Available	Available	2.34	3.98	0.82	1.41
500 psig (34,5 bar G)	max	23.0	39.4	Not Available	Not Available	66.0	112	23.0	39.4
	min	0.82	1.41	Available	Available	2.34	3.98	0.82	1.41

TABLE 9. Air Flow Rate Limits at 59 °F (15 °C)

Process Pressure	Flow Rate Limits	Minimum and Maximum Air Flow Rates for line sizes 1 1/2 inch/DN 40 through 2 inch/DN 50							
		1 1/2 Inch/DN 40				2 Inch/DN 50			
		Rosemount 8800C		Rosemount 8800CR		Rosemount 8800C		Rosemount 8800CR	
		ACFM	ACMH	ACFM	ACMH	ACFM	ACMH	ACFM	ACMH
0 psig (0 bar G)	max	212	360	79.2	134	349	593	212	360
	min	18.4	31.2	7.81	13.3	30.3	51.5	18.4	31.2
50 psig (3,45 bar G)	max	212	360	79.2	134	349	593	212	360
	min	8.76	14.9	3.72	6.32	14.5	24.6	8.76	14.9
100 psig (6,89 bar G)	max	212	360	79.2	134	349	593	212	360
	min	6.58	11.2	2.80	4.75	10.8	18.3	6.58	11.2
150 psig (10,3 bar G)	max	212	360	79.2	134	349	593	212	360
	min	5.51	9.36	2.34	3.98	9.09	15.4	5.51	9.36
200 psig (13,8 bar G)	max	212	360	79.2	134	349	593	212	360
	min	5.51	9.36	2.34	3.98	9.09	15.4	5.51	9.36
300 psig (20,7 bar G)	max	198	337	79.2	134	326	554	198	337
	min	5.51	9.36	2.34	3.98	9.09	15.4	5.51	9.36
400 psig (27,6 bar G)	max	172	293	73.0	124	284	483	172	293
	min	5.51	9.36	2.34	3.98	9.09	15.4	5.51	9.36
500 psig (34,5 bar G)	max	154	262	66.0	112	254	432	154	262
	min	5.51	9.36	2.34	3.98	9.09	15.4	5.51	9.36

TABLE 10. Air Flow Rate Limits at 59 °F (15 °C)

Process Pressure	Flow Rate Limits	Minimum and Maximum Air Flow Rates for line sizes 3 inch/DN 80 through 4 inch/DN 100							
		3 Inch/DN 80				4 Inch/DN 100			
		Rosemount 8800C		Rosemount 8800CR		Rosemount 8800C		Rosemount 8800CR	
		ACFM	ACMH	ACFM	ACMH	ACFM	ACMH	ACFM	ACMH
0 psig (0 bar G)	max	770	1308	349	593	1326	2253	770	1308
	min	66.8	114	30.3	51.5	115	195	66.8	114
50 psig (3,45 bar G)	max	770	1308	349	593	1326	2253	770	1308
	min	31.8	54.1	14.5	24.6	54.8	93.2	31.8	54.1
100 psig (6,89 bar G)	max	770	1308	349	593	1326	2253	770	1308
	min	23.9	40.6	10.8	18.3	41.1	69.8	23.9	40.6
150 psig (10,3 bar G)	max	770	1308	349	593	1326	2253	770	1308
	min	20.0	34.0	9.09	15.4	34.5	58.6	20.0	34.0
200 psig (13,8 bar G)	max	770	1308	349	593	1326	2253	770	1308
	min	20.0	34.0	9.09	15.4	34.5	58.6	20.0	34.0
300 psig (20,7 bar G)	max	718	1220	326	554	1237	2102	718	1220
	min	20.0	34.0	9.09	15.4	34.5	58.6	20.0	34.0
400 psig (27,6 bar G)	max	625	1062	284	483	1076	1828	625	1062
	min	20.0	34.0	9.09	15.4	34.5	58.6	20.0	34.0
500 psig (34,5 bar G)	max	560	951	254	432	964	1638	560	951
	min	20.0	34.0	9.09	15.4	34.5	58.6	20.0	34.0

TABLE 11. Air Flow Rate Limits at 59 °F (15 °C)

Process Pressure	Flow Rate Limits	Minimum and Maximum Air Flow Rates for line sizes 6 inch/DN 150 through 8 inch/DN 200							
		6 Inch/DN 150				8 Inch/DN 200			
		Rosemount 8800C		Rosemount 8800CR		Rosemount 8800C		Rosemount 8800CR	
		ACFM	ACMH	ACFM	ACMH	ACFM	ACMH	ACFM	ACMH
0 psig (0 bar G)	max	3009	5112	1326	2253	5211	8853	3009	5112
	min	261	443	115	195	452	768	261	443
50 psig (3,45 bar G)	max	3009	5112	1326	2253	5211	8853	3009	5112
	min	124	211	54.8	93.2	215	365	124	211
100 psig (6,89 bar G)	max	3009	5112	1326	2253	5211	8853	3009	5112
	min	93.3	159	41.1	69.8	162	276	93.3	159
150 psig (10,3 bar G)	max	3009	5112	1326	2253	5211	8853	3009	5112
	min	78.2	133	34.5	58.6	135	229	78.2	133
200 psig (13,8 bar G)	max	3009	5112	1326	2253	5211	8853	3009	5112
	min	78.2	133	34.5	58.6	135	229	78.2	133
300 psig (20,7 bar G)	max	2807	4769	1237	2102	4862	8260	2807	4769
	min	78.2	133	34.5	58.6	135	229	78.2	133
400 psig (27,6 bar G)	max	2442	4149	1076	1828	4228	7183	2442	4149
	min	78.2	133	34.5	58.6	136	229	78.2	133
500 psig (34,5 bar G)	max	2188	3717	964	1638	3789	6437	2188	3717
	min	78.2	133	34.5	58.6	136	229	78.2	133

Rosemount 8800C

TABLE 12. Air Flow Rate Limits at 59 °F (15 °C)

Process Pressure	Flow Rate Limits	Minimum and Maximum Air Flow Rates for line sizes 10 inch/DN 250 through 12 inch/DN 300							
		10 Inch/DN 250				12 Inch/DN 300			
		Rosemount 8800C		Rosemount 8800CR		Rosemount 8800C		Rosemount 8800CR	
		ACFM	ACMH	ACFM	ACMH	ACFM	ACMH	ACFM	ACMH
0 psig (0 bar G)	max	8214	13956	5211	8853	11781	20016	8214	13956
	min	712.9	1211	452	768	1022	1736	712.9	1211
50 psig (3,45 bar G)	max	8214	13956	5211	8853	11781	20016	8214	13956
	min	339.5	577	215	365	486.9	827	339.5	577
100 psig (6,89 bar G)	max	8214	13956	5211	8853	11781	20016	8214	13956
	min	254.7	433	162	276	365.4	621	254.7	433
150 psig (10,3 bar G)	max	8214	13956	5211	8853	11781	20016	8214	13956
	min	213.6	363	135	229	306.3	520	213.6	363
200 psig (13,8 bar G)	max	8214	13956	5211	8853	11781	20016	8214	13956
	min	213.6	363	135	229	306.3	520	213.6	363
300 psig (20,7 bar G)	max	7664	13021	4862	8260	10992	18675	7664	13021
	min	213.6	363	135	229	306.3	520	213.6	363
400 psig (27,6 bar G)	max	6664	11322	4228	7183	9559	16241	6664	11322
	min	213.6	363	136	229	306.3	520	213.6	363
500 psig (34,5 bar G)	max	5972	10146	3789	6437	8565	14552	5972	10146
	min	213.6	363	136	229	306.3	520	213.6	363

NOTES

The Rosemount 8800C measures the volumetric flow under operating conditions (i.e. the actual volume at the operating pressure and temperature—acfm or acmh), as shown above. However, gas volumes are strongly dependent on pressure and temperature. Therefore, gas quantities are typically stated in standard or normal conditions (e.g. Scfm or Ncmh). (Standard conditions are typically 59 °F and 14.7 psia. Normal conditions are typically 0 °C and 1 bar abs.)

The flow rate limits in standard conditions are found using the equations below:

$$\text{Standard Flow Rate} = \text{Actual Flow Rate} \times \text{Density Ratio}$$

$$\text{Density Ratio} = \frac{\text{Density at Actual (Operating) Conditions}}{\text{Density at Standard Conditions}}$$

TABLE 13. Saturated Steam Flow Rate Limits (Assumes Steam Quality is 100%)

Process Pressure	Flow Rate Limits	Minimum and Maximum Saturated Steam ⁽¹⁾ Flow Rates for line sizes 1/2 inch/DN 15 through 1 inch/DN 25							
		1/2 Inch/DN 15				1 Inch/DN 25			
		Rosemount 8800C		Rosemount 8800CR		Rosemount 8800C		Rosemount 8800CR	
		lb/hr	kg/hr	lb/hr	kg/hr	lb/hr	kg/hr	lb/hr	kg/hr
15 psig (1,03 bar G)	max	120	54.6	Not Available	Not Available	342	155	120	54.6
	min	12.8	5.81	Available	Available	34.8	15.8	12.8	5.81
25 psig (1,72 bar G)	max	158	71.7	Not Available	Not Available	449	203	158	71.7
	min	14.0	6.35	Available	Available	39.9	18.1	14.0	6.35
50 psig (3,45 bar G)	max	250	113	Not Available	Not Available	711	322	250	113
	min	17.6	8.00	Available	Available	50.1	22.7	17.6	8.00
100 psig (6,89 bar G)	max	429	194	Not Available	Not Available	1221	554	429	194
	min	23.1	10.5	Available	Available	65.7	29.8	23.1	10.5
150 psig (10,3 bar G)	max	606	275	Not Available	Not Available	1724	782	606	275
	min	27.4	12.5	Available	Available	78.1	35.4	27.4	12.5
200 psig (13,8 bar G)	max	782	354	Not Available	Not Available	2225	1009	782	354
	min	31.2	14.1	Available	Available	88.7	40.2	31.2	14.1
300 psig (20,7 bar G)	max	1135	515	Not Available	Not Available	3229	1464	1135	515
	min	37.6	17.0	Available	Available	107	48.5	37.6	17.0
400 psig (27,6 bar G)	max	1492	676	Not Available	Not Available	4244	1925	1492	676
	min	44.1	20.0	Available	Available	125	56.7	44.1	20.0
500 psig (34,5 bar G)	max	1855	841	Not Available	Not Available	5277	2393	1855	841
	min	54.8	24.9	Available	Available	156	70.7	54.8	24.9

(1) Assumes steam quality is 100%

TABLE 14. Saturated Steam Flow Rate Limits (Assumes Steam Quality is 100%)

Process Pressure	Flow Rate Limits	Minimum and Maximum Saturated Steam ⁽¹⁾ Flow Rates for line sizes 1 1/2 inch/DN 40 through 2 inch/DN 50							
		1 1/2 Inch/DN 40				2 Inch/DN 50			
		Rosemount 8800C		Rosemount 8800CR		Rosemount 8800C		Rosemount 8800CR	
		lb/hr	kg/hr	lb/hr	kg/hr	lb/hr	kg/hr	lb/hr	kg/hr
15 psig (1,03 bar G)	max	917	416	342	155	1511	685	917	416
	min	82.0	37.2	34.8	15.8	135	61.2	82.0	37.2
25 psig (1,72 bar G)	max	1204	546	449	203	1983	899	1204	546
	min	93.9	42.6	39.9	18.1	155	70.2	93.9	42.6
50 psig (3,45 bar G)	max	1904	864	711	322	3138	1423	1904	864
	min	118	53.4	50.1	22.7	195	88.3	118	53.4
100 psig (6,89 bar G)	max	3270	1483	1221	554	5389	2444	3270	1483
	min	155	70.1	65.7	29.8	255	116	155	70.1
150 psig (10,3 bar G)	max	4616	2094	1724	782	7609	3451	4616	2094
	min	184	83.2	78.1	35.4	303	137	184	83.2
200 psig (13,8 bar G)	max	5956	2702	2225	1009	9818	4453	5956	2702
	min	209	94.5	88.7	40.2	344	156	209	94.5
300 psig (20,7 bar G)	max	8644	3921	3229	1464	14248	6463	8644	3921
	min	252	114	107	48.5	415	189	252	114
400 psig (27,6 bar G)	max	11362	5154	4244	1925	18727	8494	11362	5154
	min	295	134	125	56.7	487	221	295	134
500 psig (34,5 bar G)	max	14126	6407	5277	2393	23284	10561	14126	6407
	min	367	167	156	70.7	605	274	367	167

(1) Assumes steam quality is 100%

TABLE 15. Saturated Steam Flow Rate Limits (Assumes Steam Quality is 100%)

Process Pressure	Flow Rate Limits	Minimum and Maximum Saturated Steam ⁽¹⁾ Flow Rates for line sizes 3 inch/DN 80 through 4 inch/DN 100							
		3 Inch/DN 80				4 Inch/DN 100			
		Rosemount 8800C		Rosemount 8800CR		Rosemount 8800C		Rosemount 8800CR	
		lb/hr	kg/hr	lb/hr	kg/hr	lb/hr	kg/hr	lb/hr	kg/hr
15 psig (1,03 bar G)	max	3330	1510	1511	685	5734	2601	3330	1510
	min	298	135	135	61.2	513	233	298	135
25 psig (1,72 bar G)	max	4370	1982	1983	899	7526	3414	4370	1982
	min	341	155	155	70.2	587	267	341	155
50 psig (3,45 bar G)	max	6914	3136	3138	1423	11905	5400	6914	3136
	min	429	195	195	88.3	739	335	429	195
100 psig (6,89 bar G)	max	11874	5386	5389	2444	20448	9275	11874	5386
	min	562	255	255	116	968	439	562	255
150 psig (10,3 bar G)	max	16763	7603	7609	3451	28866	13093	16763	7603
	min	668	303	303	137	1150	522	668	303
200 psig (13,8 bar G)	max	21630	9811	9818	4453	37247	16895	21630	9811
	min	759	344	344	156	1307	593	759	344
300 psig (20,7 bar G)	max	31389	14237	14248	6463	54052	24517	31389	14237
	min	914	415	415	189	1574	714	914	415
400 psig (27,6 bar G)	max	41258	18714	18727	8494	71047	32226	41258	18714
	min	1073	487	487	221	1847	838	1073	487
500 psig (34,5 bar G)	max	51297	23267	23284	10561	88334	40068	51297	23267
	min	1334	605	605	274	2297	1042	1334	605

(1) Assumes steam quality is 100%

TABLE 16. Saturated Steam Flow Rate Limits (Assumes Steam Quality is 100%)

Process Pressure	Flow Rate Limits	Minimum and Maximum Saturated Steam ⁽¹⁾ Flow Rates for line sizes 6 inch/DN 150 through 8 inch/DN 200							
		6 Inch/DN 150				8 Inch/DN 200			
		Rosemount 8800C		Rosemount 8800CR		Rosemount 8800C		Rosemount 8800CR	
		lb/hr	kg/hr	lb/hr	kg/hr	lb/hr	kg/hr	lb/hr	kg/hr
15 psig (1,03 bar G)	max	13013	5903	5734	2601	22534	10221	13013	5903
	min	1163	528	513	233	2015	914	1163	528
25 psig (1,72 bar G)	max	17080	7747	7526	3414	29575	13415	17080	7747
	min	1333	605	587	267	2308	1047	1333	605
50 psig (3,45 bar G)	max	27019	12255	11905	5400	46787	21222	27019	12255
	min	1676	760	739	335	2903	1317	1676	760
100 psig (6,89 bar G)	max	46405	21049	20448	9275	80356	36449	46405	21049
	min	2197	996	968	439	3804	1725	2197	996
150 psig (10,3 bar G)	max	65611	29761	28866	13093	113440	51455	65611	29761
	min	2610	1184	1150	522	4520	2050	2610	1184
200 psig (13,8 bar G)	max	84530	38342	37247	16895	146375	66395	84530	38342
	min	2965	1345	1307	593	5134	2329	2965	1345
300 psig (20,7 bar G)	max	122666	55640	54052	24517	212411	96348	122666	55640
	min	3572	1620	1574	714	6185	2805	3572	1620
400 psig (27,6 bar G)	max	161236	73135	71047	32226	279200	126643	161236	73135
	min	4192	1901	1847	838	7259	3293	4192	1901
500 psig (34,5 bar G)	max	200468	90931	88334	40068	347134	157457	200468	90931
	min	5212	2364	2297	1042	9025	4094	5212	2364

(1) Assumes steam quality is 100%

TABLE 17. Saturated Steam Flow Rate Limits (Assumes Steam Quality is 100%)

Process Pressure	Flow Rate Limits	Minimum and Maximum Saturated Steam ⁽¹⁾ Flow Rates for line sizes 10 inch/DN 250 through 12 inch/DN 300							
		10 Inch/DN 250				12 Inch/DN 300			
		Rosemount 8800C		Rosemount 8800CR		Rosemount 8800C		Rosemount 8800CR	
		lb/hr	kg/hr	lb/hr	kg/hr	lb/hr	kg/hr	lb/hr	kg/hr
15 psig (1,03 bar G)	max	35519	16111	22534	10221	50994	23130	35519	16111
	min	3175	1440	2015	914	4554	2066	3175	1440
25 psig (1,72 bar G)	max	46618	21146	29575	13415	66862	30328	46618	21146
	min	4570	2073	2308	1047	5218	2367	4570	2073
50 psig (3,45 bar G)	max	73748	33452	46787	21222	105774	47978	73748	33452
	min	4575	2075	2903	1317	6562	2976	4575	2075
100 psig (6,89 bar G)	max	126660	57452	80356	36449	181663	82401	126660	57452
	min	5996	2720	3804	1725	8600	3901	5996	2720
150 psig (10,3 bar G)	max	178808	81106	113440	51455	256457	116327	178808	81106
	min	7125	3232	4520	2050	10218	4635	7125	3232
200 psig (13,8 bar G)	max	230722	104654	146375	66395	330915	150101	230722	104654
	min	8092	3670	5134	2329	11607	5265	8092	3670
300 psig (20,7 bar G)	max	334810	151867	212411	96348	480203	217816	334810	151867
	min	9749	4422	6185	2805	13983	6343	9749	4422
400 psig (27,6 bar G)	max	440085	199619	279200	126643	631195	286305	440085	199619
	min	11442	5190	7259	3293	16411	7444	11442	5190
500 psig (34,5 bar G)	max	547165	248190	347134	157457	784775	355968	547165	248190
	min	14226	6453	9025	4094	20404	9255	14226	6453

(1) Assumes steam quality is 100%

PERFORMANCE SPECIFICATIONS

The following performance specifications are for the Rosemount 8800C, 8800CR, and 8800CD, except where noted. Digital performance specifications applicable to both Digital HART and FOUNDATION fieldbus output.

Accuracy

Includes linearity, hysteresis, and repeatability.

Liquids—for Reynolds Numbers over 20000

Digital and Pulse Output

±0.65% of rate

Analog Output

Same as pulse output plus an additional 0.025% of span

Note: The accuracy for the 8800CR, line sizes 6 to 12 inch (150 to 300mm), is ±1.0% of rate.

Gas and Steam—for Reynolds Numbers over 15,000

Digital and Pulse Output

±1.35% of rate

Analog Output

Same as pulse output plus an additional 0.025% of span

Note: The accuracy for the 8800CR, line sizes 6 to 12 inch (150 to 300mm), is ±1.50% of rate.

Accuracy limitations for gas and steam:

- for 1/2- and 1-in. (DN 15 and DN 25): max velocity of 220 ft/s (67.06 m/s)
- for Dual-style meters (all sizes): max velocity of 100 ft/s (30.5 m/s)

NOTE

For 1/2-in. through 4-in. (15 mm through 100 mm) line sizes, as the Meter Reynolds number decreases below the stated limit to 10000, the positive limit of the accuracy error band will increase to 2.1% for the pulse output. Example: +2.1% to -0.65% for liquids.

Repeatability

± 0.1% of actual flow rate

Stability

±0.1% of rate over one year

Process Temperature Effect

Automatic K-factor correction with user-entered process temperature

Table 18 indicates the percent change in K-factor per 100 °F (50 °C) in process temperature from reference temperature of 77 °F (25 °C) for direct pulse, or user-entered process temperature.

TABLE 18. Process Temperature Effect

Material	Percent Change in K-Factor per 100 °F (50 °C)
316L @ < 77 °F (25 °C)	+ 0.23 (+ 0,20)
316L @ > 77 °F (25 °C)	- 0.27 (- 0,24)
Hastelloy® C @ < 77 °F (25 °C)	+ 0.22 (+ 0,20)
Hastelloy® C @ > 77 °F (25 °C)	- 0.22 (- 0,20)

Ambient Temperature Effect

Digital and Pulse Outputs

No effect

Analog Output

±0.1% of span from -40 to 185 °F (-40 to 85 °C)

Vibration Effect

An output with no process flow may be detected if sufficiently high vibration is present.

The meter design will minimize this effect, and the factory settings for signal processing are selected to eliminate these errors for most applications.

If an output error at zero flow is still detected, it can be eliminated by adjusting the low flow cutoff, trigger level, or low-pass filter.

As the process begins to flow through the meter, most vibration effects are quickly overcome by the flow signal. At or near the minimum liquid flow rate in a normal pipe mounted installation, the maximum vibration should be 0.087-inch (2,21 mm) double amplitude displacement or 1 g acceleration, whichever is smaller. At or near the minimum gas flow rate in a normal pipe mounted installation, the maximum vibration should be 0.043-inch (1,09 mm) double amplitude displacement or 1/2 g acceleration, whichever is smaller.

Mounting Position Effect

Meter will meet accuracy specifications when mounted in horizontal, vertical, or inclined pipelines.

EMI/RFI Effect

HART Analog

Output error less than ±0.025% of span with twisted pair from 80-1000 MHz for radiated field strength of 10 V/m and from 0.15-80 MHz for conducted RF of 3V (tested per EN61326).

Foundation fieldbus and Digital HART

No affect on the values that are being given if using HART digital signal or FOUNDATION fieldbus.

Magnetic-Field Interference

HART Analog

Output error less than ±0.025% of span at 30 A/m (rms); meets IEC 770-1984, Section 6.2.9.

Foundation fieldbus

No effect on digital output accuracy at 30 A/m (rms). Tested per EN 61326-1.

Series Mode Noise Rejection

HART Analog

Output error less than ±0.025% of span at 1 V rms, 60 Hz; meets IEC 770-1984, Section 6.2.4.2.

Foundation fieldbus

No effect on digital output accuracy at 1 V rms 60 Hz. Meets IEC 770-1984, Section 6.2.4.2

Common Mode Noise Rejection

HART Analog

Output error less than ±0.025% of span at 30 V rms, 60 Hz; meets IEC 770-1984, Section 6.2.4.1.

Foundation fieldbus

No effect on digital output accuracy at 250 V rms, 60 Hz. According to FF-830-PS-2.0 test case 8.2.

Power Supply Effect

HART Analog

Less than 0.005% of span per volt

Foundation fieldbus

No effect on accuracy.

PHYSICAL SPECIFICATIONS

NACE Compliance

Materials of Construction meet NACE material recommendations per MR0175/ISO 15156 for sour oilfield production environments. Environmental limits apply to certain materials. Consult latest standard for details. Selected materials also conform to NACE MR0103 for refining environments.

Electrical Connections

1/2 -14 NPT, PG 13.5, or M20 x 1.5 conduit threads; screw terminals provided for 4-20 mA and pulse output connections; communicator connections permanently fixed to terminal block

Non-Wetted Materials

Housing

Low-copper aluminum (NEMA 4X, CSA Type 4X, IP66)

Paint

Polyurethane

Cover O-rings

Buna-N

Flanges

316/316L lap joint

Process-Wetted Materials

Meter Body

316L wrought stainless and CF-3M cast stainless or C-22® and C-276 wrought Hastelloy® or CW2M and CW12MW cast Hastelloy. Other material grades available. Consult factory.

Flanges

316/316L stainless steel
Hastelloy C-22® Weld Neck

Collars

Hastelloy C-22®

Surface Finish of Flanges and Collars

Standard: 125 to 250 μ inches
(3.1 to 6.3 μ meters) Ra roughness

Smooth: 63 to 125 μ inches
(1.6 to 3.1 μ meters) Ra roughness

Process Connections

Mounts between the following flange configurations:
ASME B16.5 (ANSI): Class 150, 300, 600, 900, 1500
DIN: PN 10, 16, 25, 40, 64, 100, 160
JIS: 10K, 20K, and 40K

Mounting

Integral (Standard)

Electronics are mounted on meter body

Remote (Optional)

Electronics may be mounted remote from the meter body. Interconnecting coaxial cable available in nonadjustable 10, 20, and 30 ft (3,0, 6,1, and 9,1 m) lengths. Consult factory for non-standard lengths up to 75 ft (22,9 m). Remote mounting hardware includes a polyurethane painted, carbon steel pipe mount bracket with one carbon steel u-bolt.

Temperature Limitations for Integral Mounting

The maximum process temperature for integral mount electronics is dependent on the ambient temperature where the meter is installed. The electronics must not exceed 185°F (85°C). The following is for reference, please note that the pipe was insulated with 3 inches of ceramic fiber insulator.

FIGURE 1. Rosemount 8800 Vortex Flowmeter Ambient/process temperature limits

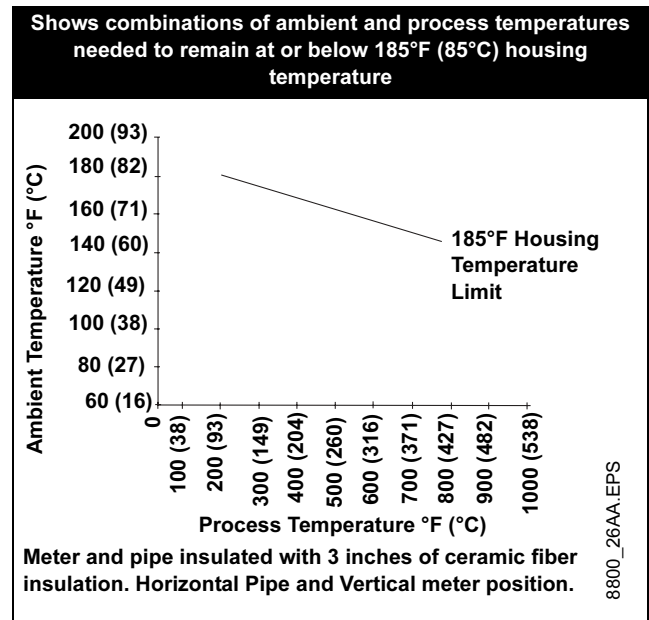

Pipe Length Requirements

The vortex meter may be installed with a minimum of ten straight pipe diameters (D) upstream and five straight pipe diameters (D) downstream by following the K-factor corrections as described in the Technical Data Sheet (00816-0100-3250) on Installation Effects. No K-factor correction is required if 35 diameters upstream (35D) and 10 diameters downstream (10D) are available.

Tagging

The flowmeter will be tagged at no charge, according to customer requirements. All tags are stainless steel. The standard tag is permanently attached to the flowmeter. Character height is 1/16-inch (1,6 mm). A wired-in tag is available on request.

Flow Calibration Information

Flowmeter calibration and configuration information is provided with every flowmeter. For a certified copy of flow calibration data, Option Q4 must be ordered in the model number.

Product Certificates

Approved Manufacturing Locations

Rosemount Inc. — Eden Prairie, Minnesota, USA

EUROPEAN DIRECTIVE INFORMATION

The EC declaration of conformity for all applicable European directives for this product can be found on our website at www.rosemount.com. A hard copy may be obtained by contacting our local sales office.

ATEX Directive

Rosemount Inc. complies with the ATEX Directive.

Flame-Proof enclosure Ex d protection type in accordance with EN50 018

- Transmitters with Flame-Proof enclosure type protection shall only be opened when power is removed.
- Closing of entries in the device must be carried out using the appropriate EEx d metal cable gland or metal blanking plug.
- Do not exceed the energy level, which is stated on the approval label.



Type n protection type in accordance with EN50 021

- Closing of entries in the device must be carried out using the appropriate EExe or EExn metal cable gland and metal blanking plug or any appropriate ATEX approved cable gland and blanking plug with IP66 rating certified by an EU approved certification body.



EUROPEAN PRESSURE EQUIPMENT DIRECTIVE (PED)

Model 8800 Vortex Flowmeter Line Size 40 mm to 300 mm

Certificate Number PED-H-20 **CE** 0434

Module H Conformity Assessment

Mandatory CE-marking for flowmeters in accordance with Article 15 of the PED can be found on the flowtube body (CE 0434).

Flowmeter categories I – IV, use module H for conformity assessment procedures.

Model 8800 Vortex Flowmeter Line Size 15 mm and 25 mm

Sound Engineering Practice

Flowmeters that are SEP or Category I with Explosion-Proof protection are outside the scope of PED and cannot be marked for compliance with PED.

HAZARDOUS LOCATION CERTIFICATIONS

Model 8800C with HART Protocol

North American Certifications

Factory Mutual (FM)

- E5** Explosion-Proof for Class I, Division 1, Groups B, C, and D; Dust-ignition proof for Class II/III, Division 1, Groups E, F, and G; Temp Code T5 ($T_a = -50^{\circ}\text{C}$ to 85°C)
Factory sealed.
- I5** Intrinsically safe for use in Class I, Division 1, Groups A, B, C, and D; Class II/III, Division 1, Groups E, F, and G; Temp. code T4; when connected in accordance with Rosemount drawings 08800-0106 and 00268-0031; Non-incendive for Class I, Division 2, Groups A, B, C, and D; Temperature Code T4
- K5** E5 and I5 combination

Canadian Standards Association (CSA)

- E6** Explosion-Proof for Class I, Division 1, Groups B, C, and D; Dust-ignition proof for Class II, Division 1, Groups E, F, and G; Class III, Division 1 Suitable for Class I, Division 2, Groups A, B, C, and D; Factory sealed.
- I6** Intrinsically safe for Class I, Division 1, Groups A, B, C, and D; When connected in accordance with Rosemount drawing 08800-0111; Temperature code T3C
- C6** E6 and I6 combination

Product Data Sheet

00813-0100-4003, Rev MB
August 2004

Rosemount 8800C

European Certifications

ATEX Intrinsic Safety and Dust Certification

I1 Certification No. BAS99ATEX1222
ATEX Marking Ex II 1 GD
EEx ia IIC T5 (-50°C ≤ Ta ≤ 40°C)
EEx ia IIC T4 (-50°C ≤ Ta ≤ 70°C)
Dust Certification T80°C (-20°C ≤ Ta ≤ 70°C)
IP 66
CE 1180
Input Parameters:
U_i = 30 VDC
I_i⁽¹⁾ = 300 mA
P_i⁽¹⁾ = 1.0 W
C_i = 0 μF
L_i = 40 μH

ATEX Type N Certification

N1 Certification No. BAS99ATEX3221
ATEX Marking Ex II 3 GD
EEx nL IIC T5 (-40°C ≤ Ta ≤ 70°C)
Dust Certification T80°C (-20°C ≤ Ta ≤ 70°C)
IP 66
Input Parameters:
U_i = 42 V dc Max
C_i = 0 μF
L_i = 40 μH

ATEX Flame-Proof Certification

ED Certification No. KEMA99ATEX3852X
ATEX Marking Remote Mount:
Transmitter: Ex II 2(1) G
EEx d [ia] IIC T6 (-50°C ≤ Ta ≤ 70°C)
Meter Body: Ex II 1 G
EEx ia IIC T6 (-50°C ≤ Ta ≤ 70°C)
ATEX Marking Integral Mount: Ex II 1/2 G
EEx d [ia] IIC T6 (-50°C ≤ Ta ≤ 70°C)
CE 1180
V = 42 Vdc Max
Um = 250V

SPECIAL CONDITIONS

When the equipment is installed particular precautions must be taken to ensure, taking account with the effect of the fluid temperature, that the ambient temperature of the electrical parts of the equipment is comprised between -50 °C and 70 °C.

The remote mounted sensor may only be connected to the transmitter with the associated cable, supplied by the manufacturer.

Model 8800C With FOUNDATION Fieldbus Protocol

North American Certifications

Factory Mutual (FM) Approvals

- E5** Explosion-Proof for
Class I, Division 1, Groups B, C, and D. Dust-Ignition Proof for
Class II/III, Division 1, Groups E, F, and G.
Factory sealed.
Temperature Code T5 (-50°C ≤ Ta ≤ 85°C)
- I5** Intrinsically safe for use in
Class I, Division 1, Groups A, B, C, and D.
Class II/III, Division 1, Groups E, F, and G.
Temp. Code T4; when connected in accordance with
Rosemount drawings 08800-0106 and 00268-0031.
Non-incendive for Class I, Division 2,
Groups A, B, C, and D.
Temperature Code T4
- IE** Fisco for Class I, Division 1, Groups A, B, C, and D.
Class II/III, Division 1, Groups E, F, and G.
Temp. Code: T4 (Ta = 40°C)
when installed per Rosemount control drawing
08800-0106 and 00268-0031.
Non-incendive for Class I, Division 2,
Groups A, B, C, and D.
Temp. Code: T4 (Ta = 40°C)
- K5** E5 and I5 combination

Canadian Standards Association (CSA) Approvals

- E6** Explosion Proof for
Class I, Division 1, Groups B, C, and D; Dust-Ignition Proof for
Class II, Division 1, Groups E, F, and G; Class III, Division 1.
Suitable for Class I, Division 2, Groups A, B, C, and D
hazardous locations.
Factory sealed.
- I6** Intrinsically Safe for
Class I, Division 1, Groups A, B, C, and D;
When connected in accordance with Rosemount drawing
08800-0111;
Temperature Code T3C.
- IF** Fisco for Class I, Division 1, Groups A, B, C, and D;
Class I, Division 2, Groups A, B, C, and D
Temperature Code: T3C
When installed per Rosemount drawing 08800-0111;
- C6** E6 and I6 combination.

(1) Total for transmitter

European Certifications

ATEX Intrinsic Safety and Dust Certification

I1 Certification No. BAS99ATEX1241X
 ATEX Marking  II 1 GD
 EEx ia IIC T4 (-50°C ≤ Ta ≤ 60°C)
 Dust Certification T80°C (-20°C ≤ Ta ≤ 60°C)
 IP 66
CE 1180
 Input Parameters:
 U_i = 30 VDC
 I_i = 300 mA
 P_i = 1.3 W
 C_i = 0 μF
 L_i = 20 μH

SPECIAL CONDITIONS FOR SAFE USE (X)

The apparatus (with T1 option) is not capable of withstanding the 500V insulation test required by EN 50020: 1994. This must be taken into account when installing the apparatus.

ATEX FISCO

IA Certification No. BAS99ATEX1241X
 ATEX Marking  II 1 GD
 EEx ia IIC T4 (-50°C ≤ Ta ≤ 60°C)
 IP66
CE 1180
 Input Parameters:
 U_i = 17.5 VDC
 I_i = 380 mA
 P_i = 5.32 W
 C_i = 0 μF
 L_i = < 10 μH

SPECIAL CONDITIONS FOR SAFE USE (X)

The apparatus (with T1 option) is not capable of withstanding the 500V insulation test required by EN 50020: 1994. This must be taken into account when installing the apparatus.



ATEX Type N Certification

N1 Certification No. BAS99ATEX3240X
 ATEX Marking  II 3 GD
 EEx nL IIC T5 (-40°C ≤ Ta ≤ 70°C)
 Dust Certification T80°C (-20°C ≤ Ta ≤ 70°C)
 IP 66
 Input Parameters:
 U_i = 42 VDC MAX
 C_i = 0 μF
 L_i = 20 μH

SPECIAL CONDITIONS FOR SAFE USE (X)

The apparatus is not capable of withstanding the 500V insulation test required by EN 50021: 1999. This must be taken into account when installing the apparatus.

ATEX Flame-Proof Certifications

ED Certification No. KEMA99ATEX3852X
 ATEX Marking Remote Mount:
 Transmitter:  II 2(1) G
 EEx d [ia] IIC T6 (-50°C ≤ Ta ≤ 70°C)
 Meter Body:  II 1 G
 EEx ia IIC T6 (-50°C ≤ Ta ≤ 70°C)
 ATEX Marking Integral Mount:  II 1/2 G
 EEx d [ia] IIC T6 (-50°C ≤ Ta ≤ 70°C)
CE 1180
 V = 42 Vdc Max
 Um = 250V

SPECIAL CONDITIONS

When the equipment is installed particular precautions must be taken to ensure, taking account with the effect of the fluid temperature, that the ambient temperature of the electrical parts of the apparatus is comprised between -50 °C and 70 °C.

The remote mounted sensor may only be connected to the transmitter with the associated cable, supplied by the manufacturer.

Dimensional Drawings

FIGURE 2. Flanged-Style Flowmeter Dimensional Drawings (1/2-through 12-in./15 through 300 mm Line Sizes)

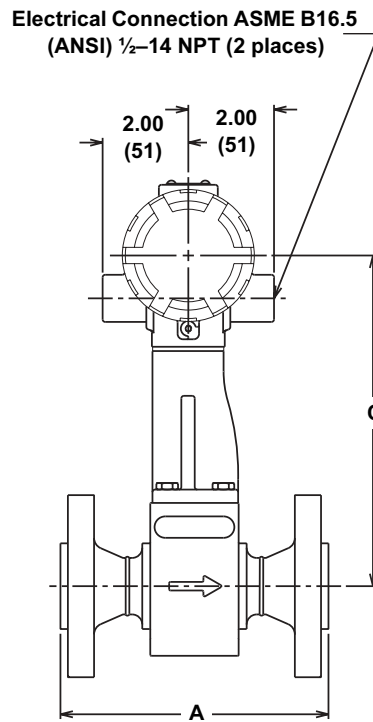
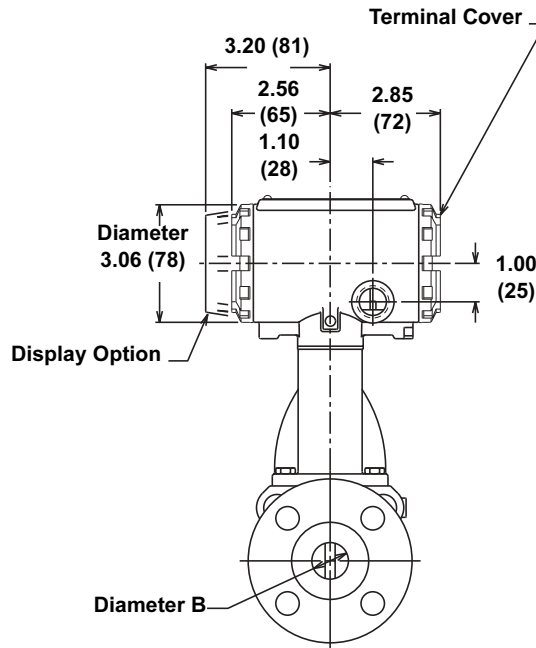

NOTE
 Dimensions are in inches (millimeters)

TABLE 19. Flanged-Style Flowmeter (¹/₂-through 3in./15 through 80 mm Line Sizes)

Nominal Size Inch (mm)	Flange Rating	Face-to-face A Inch (mm) ⁽¹⁾	A-ANSI RTJ Inch (mm)	Diameter B Inch (mm) ⁽²⁾	C Inch (mm) ⁽³⁾	Weight ⁽⁴⁾ lb (kg)	
½ (15)	Class 150	6.9 (175)	–	0.54 (13,7)	7.6 (193)	9.1 (4,1)	
	Class 300	7.2 (183)	7.7 (196)	0.54 (13,7)	7.6 (193)	10.4 (4,7)	
	Class 600	7.7 (196)	7.7 (196)	0.54 (13,7)	7.6 (193)	10.8 (4,9)	
	Class 900	8.4 (213)	8.4 (213)	0.54 (13,7)	7.6 (193)	15.3 (6,9)	
	PN 16/40	6.1 (155)	–	0.54 (13,7)	7.6 (193)	10.4 (4,7)	
	PN 100	6.6 (168)	–	0.54 (13,7)	7.6 (193)	12.3 (5,6)	
	JIS 10K/20K	6.3 (160)	–	0.54 (13,7)	7.6 (193)	10.1 (4,5)	
	JIS 40K	7.3 (185)	–	0.54 (13,7)	7.6 (193)	13.5 (6,1)	
1 (25)	Class 150	7.5 (191)	8.0 (203)	0.95 (24,1)	7.7 (196)	12.3 (5,6)	
	Class 300	8.0 (203)	8.5 (216)	0.95 (24,1)	7.7 (196)	15.0 (6,8)	
	Class 600	8.5 (216)	8.5 (216)	0.95 (24,1)	7.7 (196)	15.8 (7,2)	
	Class 900	9.4 (239)	9.4 (239)	0.95 (24,1)	7.7 (196)	24.3 (11,0)	
	Class 1500	9.4 (239)	9.4 (239)	0.95 (24,1)	7.7 (196)	24.3 (11,0)	
	PN 16/40	6.3 (160)	–	0.95 (24,1)	7.7 (196)	13.5 (6,1)	
	PN 100	7.7 (195)	–	0.95 (24,1)	7.7 (196)	19.5 (8,8)	
	PN 160	7.7 (195)	–	0.95 (24,1)	7.7 (196)	19.5 (8,8)	
	JIS 10K/20K	6.5 (165)	–	0.95 (24,1)	7.7 (196)	13.7 (6,2)	
	JIS 40K	7.9 (200)	–	0.95 (24,1)	7.7 (196)	17.4 (7,9)	
	1 ½ (40)	Class 150	8.2 (208)	8.7 (221)	1.49 (37,8)	8.1 (206)	17.6 (8,0)
Class 300		8.7 (221)	9.2 (234)	1.49 (37,8)	8.1 (206)	23.0 (10,4)	
Class 600		9.4 (239)	9.4 (239)	1.49 (37,8)	8.1 (206)	25.3 (11,5)	
Class 900		10.4 (264)	10.4 (264)	1.49 (37,8)	8.1 (206)	36.3 (16,5)	
Class 1500		10.4 (264)	10.4 (264)	1.49 (37,8)	8.1 (206)	36.6 (16,6)	
PN 16/40		6.9 (175)	–	1.49 (37,8)	8.1 (206)	19.3 (8,8)	
PN 100		8.2 (208)	–	1.49 (37,8)	8.1 (206)	27.9 (12,7)	
PN 160		8.4 (213)	–	1.49 (37,8)	8.1 (206)	29.3 (13,3)	
JIS 10K/20K		7.3 (185)	–	1.49 (37,8)	8.1 (206)	18.6 (8,4)	
JIS 40K		8.5 (215)	–	1.49 (37,8)	8.1 (206)	25.6 (11,6)	
2 (50)		Class 150	9.3 (236)	9.8 (249)	1.92 (48,8)	8.5 (216)	22.0 (10,0)
		Class 300	9.8 (249)	10.4 (264)	1.92 (48,8)	8.5 (216)	26.0 (11,8)
		Class 600	10.5 (267)	10.7 (271)	1.92 (48,8)	8.5 (216)	29.6 (13,4)
	Class 900	12.8 (325)	12.9 (328)	1.92 (48,8)	8.5 (216)	59.4 (26,9)	
	Class 1500	12.8 (325)	12.9 (328)	1.79 (45,5)	8.5 (216)	59.4 (26,9)	
	PN 16/40	8.0 (203)	–	1.92 (48,8)	8.5 (216)	23.0 (10,4)	
	PN 64	9.2 (234)	–	1.92 (48,8)	8.5 (216)	30.6 (13,9)	
	PN 100	9.6 (244)	–	1.92 (48,8)	8.5 (216)	36.4 (16,5)	
	PN 160	10.2 (259)	–	1.92 (48,8)	8.5 (216)	38.7 (17,6)	
	JIS 10K	7.7 (195)	–	1.92 (48,8)	8.5 (216)	19.5 (8,8)	
	JIS 20K	8.3 (210)	–	1.92 (48,8)	8.5 (216)	20.1 (9,1)	
	JIS 40K	9.8 (249)	–	1.92 (48,8)	8.5 (216)	28.3 (12,8)	

(1) ±0.14 inch (3.6 mm)

(2) ±0.03 inch (0.8 mm)

(3) ±0.20 inch (5.1 mm)

(4) Add 0.2 lb (0,1 kg) for display option.

Product Data Sheet

00813-0100-4003, Rev MB
August 2004

Rosemount 8800C

TABLE 20. Flanged-Style Flowmeter (4-through 12-in./100 through 300mm Line Sizes) (Refer to previous drawing)

Nominal Size Inch (mm)	Flange Rating	Face-to-face A Inch (mm) ⁽¹⁾	A ANSI RTJ Inch (mm)	Diameter B Inch (mm) ⁽²⁾	C Inch (mm) ⁽³⁾	Weight ⁽⁴⁾ lb (kg)
3 (80)	Class 150	9.9 (251)	10.4 (264)	2.87 (72,9)	9.1 (231)	36.9 (16,7)
	Class 300	10.6 (269)	11.2 (284)	2.87 (72,9)	9.1 (231)	46.1 (20,9)
	Class 600	11.4 (290)	11.5 (292)	2.87 (72,9)	9.1 (231)	52.1 (26,6)
	Class 900	12.9 (328)	13.0 (330)	2.87 (72,9)	9.1 (231)	75.5 (34,2)
	Class 1500	14.1 (358)	14.2 (361)	2.66 (67,6)	9.1 (231)	105.8 (48,0)
	PN 16/40	8.9 (226)	–	2.87 (72,9)	9.1 (231)	36.3 (16,5)
	PN 64	10.0 (254)	–	2.87 (72,9)	9.1 (231)	45.1 (20,5)
	PN 100	10.5 (267)	–	2.87 (72,9)	9.1 (231)	54.4 (24,7)
	PN 160	11.2 (284)	–	2.87 (72,9)	9.1 (231)	59.6 (27,0)
	JIS 10K	7.9 (200)	–	2.87 (72,9)	9.1 (231)	27.6 (12,5)
	JIS 20K	9.3 (235)	–	2.87 (72,9)	9.1 (231)	35.0 (15,9)
	JIS 40K	11.0 (280)	–	2.87 (72,9)	9.1 (231)	50.0 (22,7)
4 (100)	Class 150	10.3 (262)	10.8 (274)	3.79 (96,3)	9.6 (244)	50.7 (23,0)
	Class 300	11.0 (279)	11.6 (295)	3.79 (96,3)	9.6 (244)	70.8 (32,1)
	Class 600	12.8 (325)	12.9 (328)	3.79 (96,3)	9.6 (244)	96.5 (43,8)
	Class 900	13.8 (351)	13.9 (353)	3.79 (96,3)	9.6 (244)	119.7 (54,3)
	Class 1500	14.5 (368)	14.6 (371)	3.43 (87,1)	9.6 (244)	157.9 (71,6)
	PN 16	8.4 (213)	–	3.79 (96,3)	9.6 (244)	40.1 (18,2)
	PN 40	9.4 (239)	–	3.79 (96,3)	9.6 (244)	49.2 (22,3)
	PN 64	10.4 (264)	–	3.79 (96,3)	9.6 (244)	62.1 (28,2)
	PN 100	11.3 (287)	–	3.79 (96,3)	9.6 (244)	78.5 (35,6)
	PN 160	12.1 (307)	–	3.79 (96,3)	9.6 (244)	85.8 (38,9)
	JIS 10K	8.7 (220)	–	3.79 (96,3)	9.6 (244)	37.0 (16,8)
	JIS 20K	8.7 (220)	–	3.79 (96,3)	9.6 (244)	44.9 (20,4)
JIS 40K	11.8 (300)	–	3.79 (96,3)	9.6 (244)	75.3 (34,2)	
6 (150)	Class 150	11.6 (295)	12.1 (307)	5.7 (144,8)	10.8 (274)	90.0 (40,8)
	Class 300	12.4 (315)	13.0 (330)	5.7 (144,8)	10.8 (274)	129.5 (58,7)
	Class 600	14.3 (363)	14.5 (368)	5.7 (144,8)	10.8 (274)	195.5 (88,7)
	Class 900	16.1 (409)	16.2 (411)	5.7 (144,8)	10.8 (274)	253.7 (115,1)
	Class 1500	18.6 (472)	18.8 (478)	5.7 (144,8)	10.8 (274)	376.0 (170,6)
	PN 16	8.9 (226)	–	5.7 (144,8)	10.8 (274)	75.6 (34,3)
	PN 40	10.5 (267)	–	5.7 (144,8)	10.8 (274)	95.3 (43,2)
	PN 64	12.1 (307)	–	5.7 (144,8)	10.8 (274)	138.8 (63,0)
	PN 100	13.7 (348)	–	5.7 (144,8)	10.8 (274)	168.5 (76,4)
	JIS 10K	10.6 (270)	–	5.7 (144,8)	10.8 (274)	79.8 (36,2)
	JIS 20K	10.6 (270)	–	5.7 (144,8)	10.8 (274)	97.7 (44,3)
	JIS 40K	14.2 (360)	–	5.7 (144,8)	10.8 (274)	175.9 (79,8)

(1) ±0.14 inch (3.6 mm)

(2) ±0.03 inch (0.8 mm)

(3) ±0.20 inch (5.1 mm)

(4) Add 0.2 lb (0,1 kg) for display option.

TABLE 21. Flanged-Style Flowmeter (4-through 12-in./100 through 300mm Line Sizes) (Refer to previous drawing)

Nominal Size Inch (mm)	Flange Rating	Face-to-face A Inch (mm) ⁽¹⁾	A ANSI RTJ Inch (mm)	Diameter B Inch (mm) ⁽²⁾	C Inch (mm) ⁽³⁾	Weight ⁽⁴⁾ lb (kg)
8 (200)	Class 150	13.6 (345)	14.1 (358)	7.55 (191,8)	11.7 (297)	139.6 (63,3)
	Class 300	14.3 (363)	15.0 (381)	7.55 (191,8)	11.7 (297)	196.2 (89,0)
	Class 600	16.6 (422)	16.7 (424)	7.55 (191,8)	11.7 (297)	295.0 (133,8)
	Class 900	18.8 (478)	19.0 (483)	7.55 (191,8)	11.7 (297)	420.4 (190,7)
	Class 1500	22.8 (579)	23.2 (589)	7.55 (191,8)	11.7 (297)	646.0 (293,0)
	PN 10	10.5 (266)	–	7.55 (191,8)	11.7 (297)	109.6 (49,7)
	PN 16	10.5 (266)	–	7.55 (191,8)	11.7 (297)	108.5 (49,2)
	PN 25	11.9 (302)	–	7.55 (191,8)	11.7 (297)	136.3 (61,8)
	PN 40	12.5 (318)	–	7.55 (191,8)	11.7 (297)	154.8 (70,2)
	PN 64	14.2 (361)	–	7.55 (191,8)	11.7 (297)	214.6 (97,3)
	PN 100	15.8 (401)	–	7.55 (191,8)	11.7 (297)	279.9 (127)
	JIS 10K	12.2 (310)	–	7.55 (191,8)	11.7 (297)	109.9 (49,9)
	JIS 20K	12.2 (310)	–	7.55 (191,8)	11.7 (297)	134.3 (60,9)
	JIS 40K	16.5 (420)	–	7.55 (191,8)	11.7 (297)	255.7 (116)
10 (250)	Class 150	14.6 (371)	15.1 (384)	9.56 (243)	12.8 (325)	197.2 (89)
	Class 300	15.8 (401)	16.4 (417)	9.56 (243)	12.8 (325)	285.2 (129)
	Class 600	19.1 (485)	19.2 (488)	9.56 (243)	12.8 (325)	475.3 (216)
	Class 900	21.6 (549)	21.7 (551)	9.56 (243)	12.8 (325)	623.1 (282,6)
	Class 1500	27.1 (688)	27.4 (696)	9.56 (243)	12.8 (325)	1126.0 (510,7)
	PN 10	11.9 (302)	–	9.56 (243)	12.8 (325)	156.3 (71)
	PN 16	12.1 (307)	–	9.56 (243)	12.8 (325)	161.1 (73)
	PN 25	13.5 (343)	–	9.56 (243)	12.8 (325)	197.4 (90)
	PN 40	14.8 (376)	–	9.56 (243)	12.8 (325)	245.3 (111)
	PN 64	16.4 (417)	–	9.56 (243)	12.8 (325)	306.3 (139)
	PN 100	18.9 (480)	–	9.56 (243)	12.8 (325)	443.0 (201)
	JIS 10K	14.6 (371)	–	9.56 (243)	12.8 (325)	173.3 (79)
	JIS 20K	14.6 (371)	–	9.56 (243)	12.8 (325)	220.5 (100)
	JIS 40K	18.1 (460)	–	9.56 (243)	12.8 (325)	377.3 (171)
12 (300)	Class 150	16.8 (427)	17.3 (439)	11.38 (289)	13.7 (348)	296.0 (134)
	Class 300	18.0 (457)	18.7 (475)	11.38 (289)	13.7 (348)	413.2 (187)
	Class 600	20.5 (521)	20.7 (526)	11.38 (289)	13.7 (348)	592.2 (269)
	Class 900	24.1 (612)	24.2 (615)	11.38 (289)	13.7 (348)	844.0 (383,0)
	Class 1500	30.5 (775)	31.2 (792)	11.38 (289)	13.7 (348)	1697.0 (769,7)
	PN 10	13.2 (335)	–	11.38 (289)	13.7 (348)	203.1 (92)
	PN 16	13.9 (353)	–	11.38 (289)	13.7 (348)	223.4 (101)
	PN 25	15.0 (381)	–	11.38 (289)	13.7 (348)	267.8 (121)
	PN 40	16.9 (429)	–	11.38 (289)	13.7 (348)	345.7 (157)
	PN 64	18.8 (478)	–	11.38 (289)	13.7 (348)	428.5 (194)
	PN 100	21.2 (538)	–	11.38 (289)	13.7 (348)	640.8 (291)
	JIS 10K	15.7 (399)	–	11.38 (289)	13.7 (348)	224.5 (102)
	JIS 20K	15.7 (399)	–	11.38 (289)	13.7 (348)	287.1 (130)
	JIS 40K	19.7 (500)	–	11.38 (289)	13.7 (348)	504.7 (229)

(1) ±0.14 inch (3.6 mm)

(2) ±0.03 inch (0.8 mm)

(3) ±0.20 inch (5.1 mm)

(4) Add 0.2 lb (0,1 kg) for display option.

FIGURE 3. Rosemount 8800CR Reduce Flowmeter Dimensional Drawings (1-through 12-in./25 through 300 mm Line Sizes)

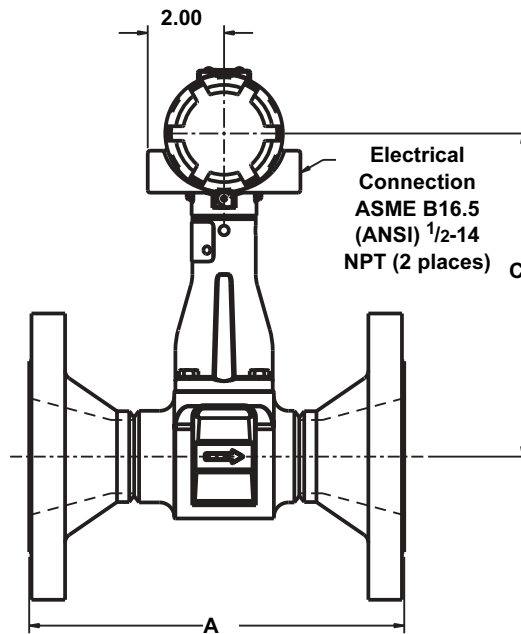
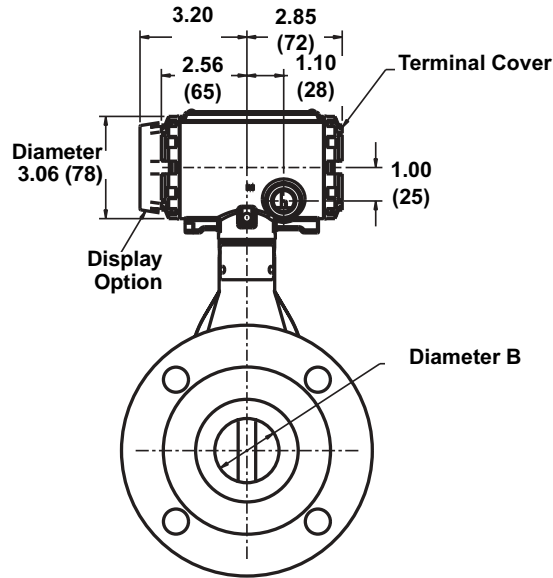

NOTE
 Dimensions are in inches (millimeters)

8800_22a, 8800_22ab

Rosemount 8800C

TABLE 22. Reducer Flowmeter (1-through 3in./25 through 80 mm Line Sizes)

Nominal Size Inch (mm)	Flange Rating	Face-to-face A Inch (mm) ⁽¹⁾	A-ANSI RTJ Inch (mm)	Diameter B Inch (mm) ⁽²⁾	C Inch (mm) ⁽³⁾	Weight ⁽⁴⁾ lb (kg)
1 (25)	Class 150	7.5 (191)	8.0 (203)	0.54 (13,7)	7.6 (193)	11.56 (5,24)
	Class 300	8.0 (203)	8.5 (216)	0.54 (13,7)	7.6 (193)	14.22 (6,45)
	Class 600	8.5 (216)	8.5 (216)	0.54 (13,7)	7.6 (193)	15.11 (6,85)
	PN 16/40	6.3 (160)	–	0.54 (13,7)	7.6 (193)	12.64 (5,73)
	PN 100	7.7 (195)	–	0.54 (13,7)	7.6 (193)	18.44 (8,36)
1 ½ (40)	Class 150	8.2 (208)	8.7 (221)	0.95 (24,1)	7.7 (196)	15.81 (7,17)
	Class 300	8.7 (221)	9.2 (234)	0.95 (24,1)	7.7 (196)	21.20 (9,62)
	Class 600	9.4 (239)	9.4 (239)	0.95 (24,1)	7.7 (196)	23.77 (10,78)
	Class 900	10.4 (264)	10.4 (264)	0.95 (24,1)	7.7 (196)	34.98 (15,87)
	PN 16/40	6.9 (175)	–	0.95 (24,1)	7.7 (196)	17.50 (7,94)
	PN 100	8.2 (208)	–	0.95 (24,1)	7.7 (196)	26.20 (11,88)
	PN 160	8.4 (213)	–	0.95 (24,1)	7.7 (196)	27.67 (12,55)
2 (50)	Class 150	9.3 (236)	9.8 (249)	1.49 (37,8)	8.1 (206)	22.61 (10,26)
	Class 300	9.8 (249)	10.4 (264)	1.49 (37,8)	8.1 (206)	26.76 (12,14)
	Class 600	10.5 (267)	10.7 (271)	1.49 (37,8)	8.1 (206)	30.59 (13,88)
	Class 900	12.8 (325)	12.9 (328)	1.49 (37,8)	8.1 (206)	60.76 (27,56)
	PN 16/40	8.0 (203)	–	1.49 (37,8)	8.1 (206)	23.52 (10,67)
	PN 64	9.2 (234)	–	1.49 (37,8)	8.1 (206)	31.28 (14,19)
	PN 100	9.6 (244)	–	1.49 (37,8)	8.1 (206)	37.25 (16,90)
	PN 160	10.2 (259)	–	1.49 (37,8)	8.1 (206)	39.64 (17,98)
3 (80)	Class 150	9.9 (251)	10.4 (264)	1.92 (48,8)	8.5 (216)	33.15 (15,04)
	Class 300	10.6 (269)	11.2 (284)	1.92 (48,8)	8.5 (216)	42.66 (19,35)
	Class 600	11.4 (290)	11.5 (292)	1.92 (48,8)	8.5 (216)	49.46 (22,43)
	Class 900	12.9 (328)	13.0 (330)	1.92 (48,8)	8.5 (216)	73.28 (33,24)
	PN 16/40	8.9 (226)	–	1.92 (48,8)	8.5 (216)	33.30 (15,10)
	PN 64	10.0 (254)	–	1.92 (48,8)	8.5 (216)	42.45 (19,25)
	PN 100	10.5 (267)	–	1.92 (48,8)	8.5 (216)	52.21 (23,68)
	PN 160	11.2 (284)	–	1.92 (48,8)	8.5 (216)	57.94 (26,28)

(1) ±0.14 inch (3.6 mm)

(2) ±0.03 inch (0.8 mm)

(3) ±0.20 inch (5.1 mm)

(4) Add 0.2 lb (0,1 kg) for display option.

TABLE 23. Reducer Flowmeter (4-through 12-in./100 through 300mm Line Sizes) (Refer to previous drawing)

Nominal Size Inch (mm)	Flange Rating	Face-to-face A Inch (mm) ⁽¹⁾	A ANSI RTJ Inch (mm)	Diameter B Inch (mm) ⁽²⁾	C Inch (mm) ⁽³⁾	Weight ⁽⁴⁾ lb (kg)
4 (100)	Class 150	10.3 (262)	10.8 (274)	2.87 (72,9)	9.1 (231)	46.33 (21,01)
	Class 300	11.0 (279)	11.6 (295)	2.87 (72,9)	9.1 (231)	67.04 (30,41)
	Class 600	12.8 (325)	12.9 (328)	2.87 (72,9)	9.1 (231)	94.26 (42,76)
	Class 900	13.8 (351)	13.9 (353)	2.87 (72,9)	9.1 (231)	118.04 (53,54)
	PN 16	8.4 (213)	–	2.87 (72,9)	9.1 (231)	36.36 (16,49)
	PN 40	9.4 (239)	–	2.87 (72,9)	9.1 (231)	45.89 (20,81)
	PN 64	10.4 (264)	–	2.87 (72,9)	9.1 (231)	59.72 (27,09)
	PN 100	11.3 (287)	–	2.87 (72,9)	9.1 (231)	76.73 (34,80)
6 (150)	Class 150	11.6 (295)	12.1 (307)	3.79 (96,3)	9.6 (244)	70.27 (31,87)
	Class 300	12.4 (315)	13.0 (330)	3.79 (96,3)	9.6 (244)	113.09 (51,30)
	Class 600	14.3 (363)	14.5 (368)	3.79 (96,3)	9.6 (244)	185.13 (83,97)
	Class 900	16.1 (409)	16.2 (411)	3.79 (96,3)	9.6 (244)	246.33 (111,73)
	PN 16	8.9 (226)	–	3.79 (96,3)	9.6 (244)	59.20 (26,85)
	PN 40	10.5 (267)	–	3.79 (96,3)	9.6 (244)	81.94 (37,17)
	PN 64	12.1 (307)	–	3.79 (96,3)	9.6 (244)	125.36 (56,86)
	PN 100	13.7 (348)	–	3.79 (96,3)	9.6 (244)	162.29 (73,61)
8 (200)	Class 150	13.6 (345)	14.1 (358)	5.70 (144,8)	10.8 (274)	133.14 (60,39)
	Class 300	14.3 (363)	15.0 (381)	5.70 (144,8)	10.8 (274)	195.54 (88,69)
	Class 600	16.6 (422)	16.7 (424)	5.70 (144,8)	10.8 (274)	305.18 (138,43)
	PN 10	10.5 (266)	–	5.70 (144,8)	10.8 (274)	100.92 (45,78)
	PN 16	10.5 (266)	–	5.70 (144,8)	10.8 (274)	100.92 (45,78)
	PN 25	11.9 (302)	–	5.70 (144,8)	10.8 (274)	134.05 (60,80)
	PN 40	12.5 (318)	–	5.70 (144,8)	10.8 (274)	155.00 (70,31)
	PN 64	14.2 (361)	–	5.70 (144,8)	10.8 (274)	220.68 (100,10)
10 (250)	Class 150	14.6 (371)	15.1 (384)	7.55 (191,8)	11.7 (297)	182.45 (82,76)
	Class 300	15.8 (401)	16.4 (417)	7.55 (191,8)	11.7 (297)	281.66 (127,76)
	Class 600	19.1 (485)	19.2 (488)	7.55 (191,8)	11.7 (297)	489.89 (222,21)
	PN 10	11.9 (302)	–	7.55 (191,8)	11.7 (297)	138.63 (62,88)
	PN 16	12.1 (307)	–	7.55 (191,8)	11.7 (297)	148.58 (67,39)
	PN 25	13.5 (343)	–	7.55 (191,8)	11.7 (297)	191.00 (86,64)
	PN 40	14.8 (376)	–	7.55 (191,8)	11.7 (297)	245.85 (111,52)
	PN 64	16.4 (417)	–	7.55 (191,8)	11.7 (297)	314.13 (142,49)
12 (300)	Class 150	16.8 (427)	17.3 (439)	9.56 (242,8)	12.8 (325)	281.98 (127,90)
	Class 300	18.0 (457)	18.7 (475)	9.56 (242,8)	12.8 (325)	412.18 (186,96)
	Class 600	20.5 (521)	20.7 (526)	9.56 (242,8)	12.8 (325)	609.89 (296,64)
	PN 10	13.2 (335)	–	9.56 (242,8)	12.8 (325)	188.28 (85,40)
	PN 16	13.9 (353)	–	9.56 (242,8)	12.8 (325)	211.79 (96,07)
	PN 25	15.0 (381)	–	9.56 (242,8)	12.8 (325)	262.45 (119,05)
	PN 40	16.9 (429)	–	9.56 (242,8)	12.8 (325)	349.92 (158,72)
	PN 64	18.8 (478)	–	9.56 (242,8)	12.8 (325)	444.21 (201,49)
PN 100	21.2 (538)	–	9.56 (242,8)	12.8 (325)	672.07 (304,85)	

(1) ±0.14 inch (3.6 mm)

(2) ±0.03 inch (0.8 mm)

(3) ±0.20 inch (5.1 mm)

(4) Add 0.2 lb (0,1 kg) for display option.

FIGURE 4. Wafer-Style Dimensional Drawings (1/2-through 8 in./15 through 200 mm Line Sizes)

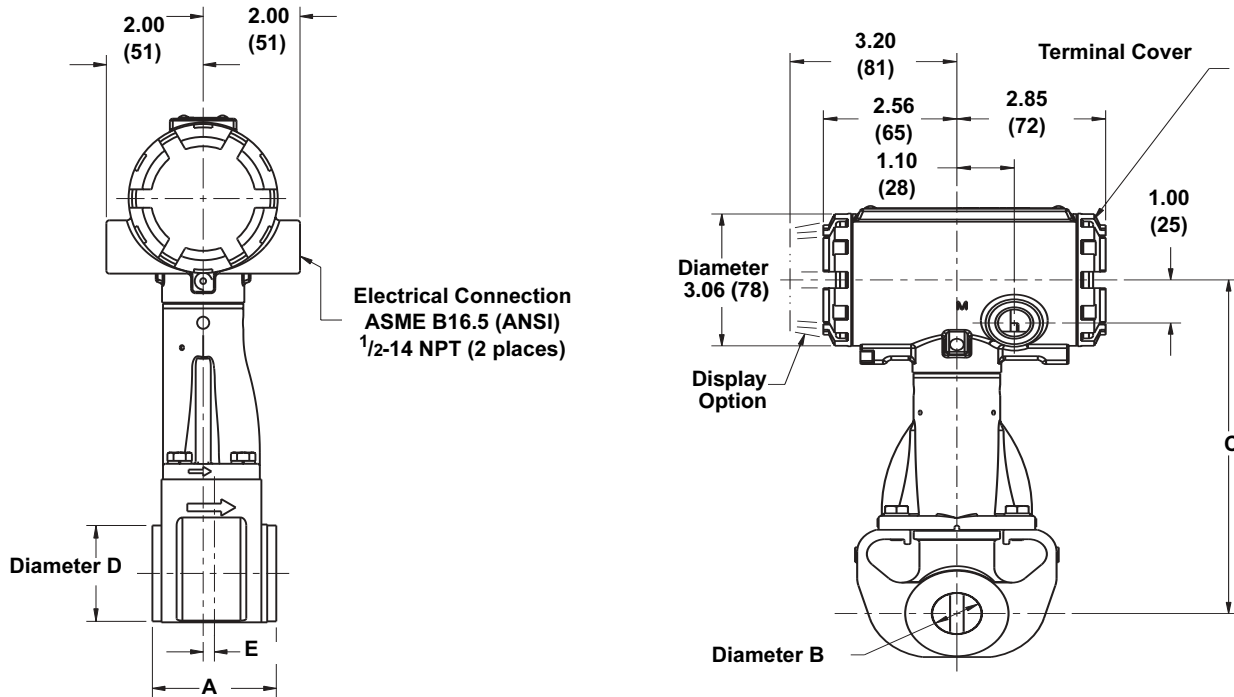

NOTE
Dimensions are in inches (millimeters)
Electronics housing may be rotated in 90 degree increments

8800-8800_33AA, 8800_32AA.EPS

TABLE 24. Rosemount 8800C Wafer-Style Meter

Nominal Size Inch (mm)	Face-to-face A Inch (mm) ⁽¹⁾	Diameter B Inch (mm) ⁽²⁾	C Inch (mm) ⁽³⁾	Diameter D Inch (mm)	E Inch (mm)	Weight lb (kg) ⁽⁴⁾
1/2 (15)	2.56 (65)	0.54 (13,7)	7.63 (194)	1.38 (35,1)	0.23 (5,9)	7.3 (3,3)
1 (25)	2.56 (65)	0.95 (24,1)	7.74 (197)	1.98 (50,3)	0.23 (5,9)	7.4 (3,4)
1 1/2 (40)	2.56 (65)	1.49 (37,8)	8.14 (207)	2.87 (72,9)	0.18 (4,6)	10.0 (4,5)
2 (50)	2.56 (65)	1.92 (49)	8.85 (225)	3.86 (98)	0.12 (3)	10.6 (4,8)
3 (80)	2.56 (65)	2.87 (73)	9.62 (244)	5.00 (127)	0.25 (6)	13.6 (6,2)
4 (100)	3.42 (87)	3.79 (96)	10.48 (266)	6.20 (158)	0.44 (11)	21.4 (9,7)
6 (150)	4.99 (127)	5.70 (145)	10.75 (273)	8.50 (216)	1.11 (28)	49.1 (22,3)
8 (200)	6.60 (168)	7.55 (192)	11.67 (296)	10.62 (270)	0.89 (23)	85 (38,6)

(1) ±0.14 inch (3.6 mm)

(2) ±0.03 inch (0.8 mm)

(3) ±0.20 inch (5.1 mm)

(4) Add 0.2 lb (0,1 kg) for display option.

Product Data Sheet

00813-0100-4003, Rev MB
August 2004

Rosemount 8800C

FIGURE 5. Vortex Dual-Sensor Style Flowmeter Dimensional Drawings (1/2-through 8-in./15 through 200 mm Line Sizes)

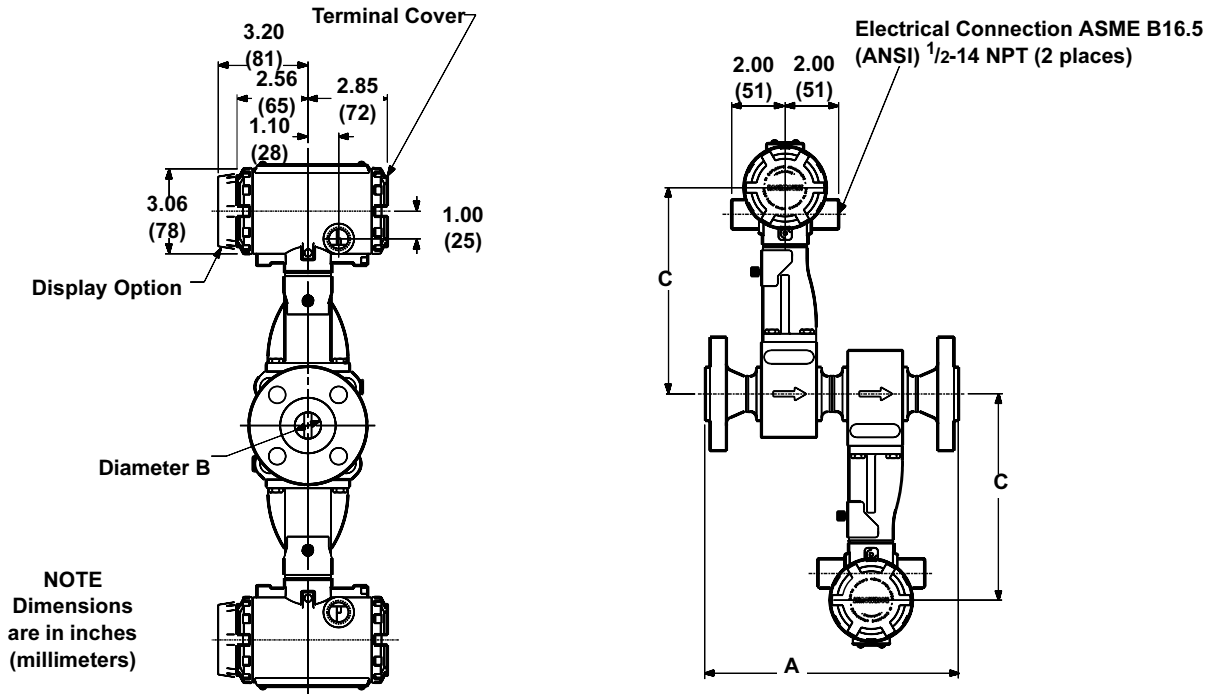

FIGURE 6. Vortex Dual-Sensor Style Flowmeter Dimensional Drawings (10-through 12-in./250 through 300 mm Line Sizes)

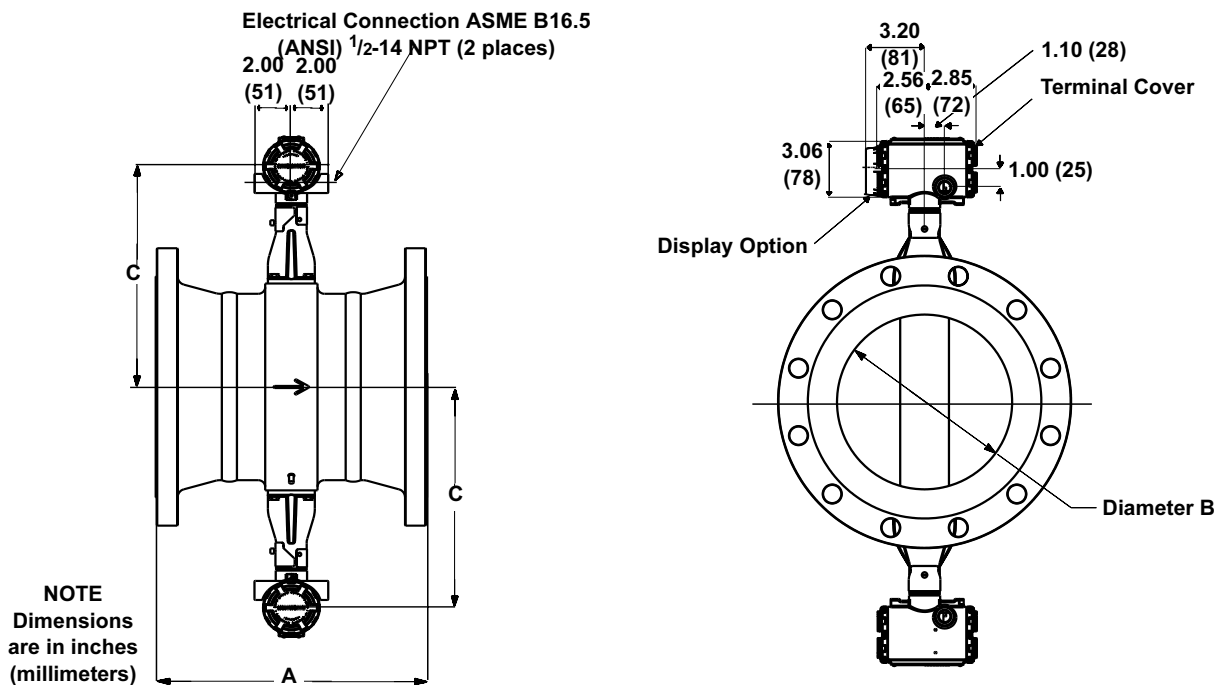

TABLE 25. Vortex Dual-Sensor Style Flowmeter (¹/₂-through 3-in./15 through 80 mm Line Sizes)

Nominal Size Inch (mm)	Flange Rating	Face-to-face A Inch (mm) ⁽¹⁾	A ANSI RTJ Inch (mm)	Diameter B Inch (mm) ⁽²⁾	C Inch (mm) ⁽³⁾	Weight lb (kg) ⁽⁴⁾	
½ (15)	Class 150	12.0 (305)	–	0.54 (13,7)	7.6 (193)	16.2 (7,4)	
	Class 300	12.3 (312)	12.8 (325)	0.54 (13,7)	7.6 (193)	17.4 (7,9)	
	Class 600	12.8 (325)	12.8 (325)	0.54 (13,7)	7.6 (193)	17.9 (8,1)	
	PN 16/40	11.2 (284)	–	0.54 (13,7)	7.6 (193)	17.2 (7,8)	
	PN 100	11.8 (300)	–	0.54 (13,7)	7.6 (193)	19.2 (8,7)	
	JIS 10K/20K	11.4 (290)	–	0.54 (13,7)	7.6 (193)	17.1 (7,8)	
	JIS 40K	12.4 (315)	–	0.54 (13,7)	7.6 (193)	20.6 (9,3)	
1 (25)	Class 150	15.1 (384)	15.6 (396)	0.95 (24,1)	7.7 (196)	19.8 (9,0)	
	Class 300	15.6 (396)	16.1 (409)	0.95 (24,1)	7.7 (196)	22.5 (10,2)	
	Class 600	16.1 (409)	16.1 (409)	0.95 (24,1)	7.7 (196)	23.3 (10,6)	
	Class 900	17.0 (432)	17.0 (432)	0.95 (24,1)	7.7 (196)	31.8 (14,4)	
	PN 16/40	13.9 (353)	–	0.95 (24,1)	7.7 (196)	21.0 (9,5)	
	PN 100	15.3 (389)	–	0.95 (24,1)	7.7 (196)	27.0 (12,3)	
	PN 160	15.3 (389)	–	0.95 (24,1)	7.7 (196)	27.0 (12,3)	
	JIS 10K/20K	14.1 (358)	–	0.95 (24,1)	7.7 (196)	22.1 (10,0)	
	JIS 40K	15.5 (394)	–	0.95 (24,1)	7.7 (196)	25.8 (11,7)	
1 ½ (40)	Class 150	11.3 (287)	11.8 (300)	1.49 (37,8)	8.1 (206)	27.0 (12,3)	
	Class 300	11.8 (300)	12.3 (312)	1.49 (37,8)	8.1 (206)	32.4 (14,7)	
	Class 600	12.5 (318)	12.5 (318)	1.49 (37,8)	8.1 (206)	34.8 (15,8)	
	Class 900	13.5 (343)	13.5 (343)	1.49 (37,8)	8.1 (206)	45.7 (20,7)	
	PN 16/40	10.0 (254)	–	1.49 (37,8)	8.1 (206)	28.7 (13,0)	
	PN 100	11.3 (287)	–	1.49 (37,8)	8.1 (206)	37.4 (17,0)	
	PN 160	11.5 (292)	–	1.49 (37,8)	8.1 (206)	38.8 (17,6)	
	JIS 10K/20K	10.4 (264)	–	1.49 (37,8)	8.1 (206)	27.9 (12,6)	
	JIS 40K	11.5 (292)	–	1.49 (37,8)	8.1 (206)	34.9 (15,8)	
2 (50)	Class 150	13.0 (330)	13.6 (345)	1.92 (48,8)	8.5 (216)	31.9 (14,5)	
	Class 300	13.6 (345)	14.1 (358)	1.92 (48,8)	8.5 (216)	35.9 (16,3)	
	Class 600	14.3 (363)	14.3 (363)	1.92 (48,8)	8.5 (216)	39.5 (17,9)	
	Class 900	16.6 (422)	16.7 (424)	1.92 (48,8)	8.5 (216)	69.2 (31,4)	
	PN 16/40	11.8 (300)	–	1.92 (48,8)	8.5 (216)	32.9 (14,9)	
	PN 64	12.9 (328)	–	1.92 (48,8)	8.5 (216)	40.5 (18,4)	
	PN 100	13.4 (340)	–	1.92 (48,8)	8.5 (216)	46.2 (21,0)	
	PN 160	14.0 (356)	–	1.92 (48,8)	8.5 (216)	48.5 (22,0)	
	JIS 10K	11.5 (292)	–	1.92 (48,8)	8.5 (216)	29.1 (13,2)	
	JIS 20K	12.1 (307)	–	1.92 (48,8)	8.5 (216)	29.7 (13,5)	
	JIS 40K	13.6 (345)	–	1.92 (48,8)	8.5 (216)	37.9 (17,2)	
	3 (80)	Class 150	14.3 (363)	14.8 (376)	2.87 (72,9)	9.1 (231)	50.3 (22,8)
		Class 300	15.0 (381)	15.7 (399)	2.87 (72,9)	9.1 (231)	59.5 (27,0)
Class 600		15.8 (401)	15.8 (401)	2.87 (72,9)	9.1 (231)	65.5 (29,7)	
Class 900		17.3 (439)	17.4 (442)	2.87 (72,9)	9.1 (231)	88.9 (40,3)	
PN 16/40		13.4 (340)	–	2.87 (72,9)	9.1 (231)	49.7 (22,5)	
PN 64		14.5 (367)	–	2.87 (72,9)	9.1 (231)	58.5 (26,5)	
PN 100		14.9 (378)	–	2.87 (72,9)	9.1 (231)	67.8 (30,8)	
PN 160		15.6 (396)	–	2.87 (72,9)	9.1 (231)	73.0 (33,1)	
JIS 10K		12.3 (312)	–	2.87 (72,9)	9.1 (231)	41.0 (18,6)	
JIS 20K		13.7 (348)	–	2.87 (72,9)	9.1 (231)	48.4 (22,0)	
JIS 40K		15.5 (394)	–	2.87 (72,9)	9.1 (231)	63.4 (28,8)	

(1) ±0.14 inch (3.6 mm)

(2) ±0.03 inch (0.8 mm)

(3) ±0.20 inch (5.1 mm)

(4) Add 0.4 lb (0,2 kg) for display option.

Product Data Sheet

00813-0100-4003, Rev MB
August 2004

Rosemount 8800C

TABLE 26. Vortex Dual-Sensor Style Flowmeter (4- through 12-in./100 through 300 mm Line Sizes)

Nominal Size Inch (mm)	Flange Rating	Face-to-face A Inch (mm) ⁽¹⁾	A ANSI RTJ Inch (mm)	Diameter B Inch (mm) ⁽²⁾	C Inch (mm) ⁽³⁾	Weight lb (kg) ⁽⁴⁾	
4 (100)	Class 150	15.2 (386)	15.7 (399)	3.79 (96,3)	9.6 (244)	68.1 (30,9)	
	Class 300	16.0 (406)	16.6 (422)	3.79 (96,3)	9.6 (244)	88.2 (40,0)	
	Class 600	17.7 (450)	17.7 (450)	3.79 (96,3)	9.6 (244)	113.9 (51,7)	
	Class 900	18.7 (475)	18.9 (480)	3.79 (96,3)	9.6 (244)	137.1 (62,2)	
	PN 16	13.3 (338)	–	3.79 (96,3)	9.6 (244)	57.6 (26,1)	
	PN 40	14.4 (366)	–	3.79 (96,3)	9.6 (244)	66.6 (30,2)	
	PN 64	15.4 (391)	–	3.79 (96,3)	9.6 (244)	79.6 (36,1)	
	PN 100	16.3 (414)	–	3.79 (96,3)	9.6 (244)	95.9 (43,5)	
	PN 160	17.1 (434)	–	3.79 (96,3)	9.6 (244)	103.2 (46,8)	
	JIS 10K	13.6 (345)	–	3.79 (96,3)	9.6 (244)	55.4 (25,1)	
	JIS 20K	13.6 (345)	–	3.79 (96,3)	9.6 (244)	63.2 (28,7)	
	JIS 40K	16.8 (427)	–	3.79 (96,3)	9.6 (244)	93.7 (42,5)	
	6 (150)	Class 150	19.4 (493)	19.9 (505)	5.7 (144,8)	10.8 (274)	126.4 (57,3)
		Class 300	20.2 (513)	20.8 (528)	5.7 (144,8)	10.8 (274)	165.9 (75,3)
Class 600		22.2 (564)	22.3 (566)	5.7 (144,8)	10.8 (274)	231.9 (105,2)	
PN 16		16.8 (427)	–	5.7 (144,8)	10.8 (274)	112.0 (50,8)	
PN 40		18.3 (465)	–	5.7 (144,8)	10.8 (274)	131.7 (59,7)	
PN 64		19.9 (505)	–	5.7 (144,8)	10.8 (274)	175.2 (79,5)	
PN 100		21.5 (546)	–	5.7 (144,8)	10.8 (274)	204.8 (92,9)	
JIS 10K		18.5 (470)	–	5.7 (144,8)	10.8 (274)	124.0 (56,2)	
JIS 20K		18.5 (470)	–	5.7 (144,8)	10.8 (274)	141.9 (64,4)	
JIS 40K		22.0 (559)	–	5.7 (144,8)	10.8 (274)	220.1 (99,8)	
8 (200)		Class 150	24.0 (610)	24.5 (622)	7.55 (191,8)	11.7 (297)	190.1 (86,2)
		Class 300	24.8 (630)	25.4 (645)	7.55 (191,8)	11.7 (297)	246.7 (111,9)
		Class 600	27.0 (686)	27.1 (688)	7.55 (191,8)	11.7 (297)	345.5 (156,7)
		PN 10	20.9 (531)	–	7.55 (191,8)	11.7 (297)	160.2 (72,7)
	PN 16	20.9 (531)	–	7.55 (191,8)	11.7 (297)	159.0 (72,1)	
	PN 25	22.3 (566)	–	7.55 (191,8)	11.7 (297)	186.9 (83,4)	
	PN 40	22.9 (582)	–	7.55 (191,8)	11.7 (297)	205.4 (93,2)	
	PN 64	24.7 (627)	–	7.55 (191,8)	11.7 (297)	265.1 (120,2)	
	PN 100	26.3 (668)	–	7.55 (191,8)	11.7 (297)	330.4 (149,9)	
	JIS 10K	22.6 (574)	–	7.55 (191,8)	11.7 (297)	178.2 (80,8)	
	JIS 20K	22.6 (574)	–	7.55 (191,8)	11.7 (297)	202.6 (91,9)	
	JIS 40K	27.0 (686)	–	7.55 (191,8)	11.7 (297)	324.0 (147,0)	
	10 (250)	Class 150	14.6 (371)	15.1 (384)	9.56 (243)	12.8 (325)	201.5 (91)
		Class 300	15.8 (401)	16.4 (417)	9.56 (243)	12.8 (325)	289.5 (131)
Class 600		19.1 (485)	19.2 (488)	9.56 (243)	12.8 (325)	479.6 (218)	
PN 10		11.9 (302)	–	9.56 (243)	12.8 (325)	160.6 (73)	
PN 16		12.1 (307)	–	9.56 (243)	12.8 (325)	165.4 (75)	
PN 25		13.5 (343)	–	9.56 (243)	12.8 (325)	210.7 (96)	
PN 40		14.8 (376)	–	9.56 (243)	12.8 (325)	249.6 (113)	
PN 64		16.4 (417)	–	9.56 (243)	12.8 (325)	310.6 (141)	
PN 100		18.9 (480)	–	9.56 (243)	12.8 (325)	447.3 (203)	
JIS 10K		14.6 (371)	–	9.56 (243)	12.8 (325)	177.6 (81)	
JIS 20K		14.6 (371)	–	9.56 (243)	12.8 (325)	224.8 (102)	
JIS 40K		18.1 (460)	–	9.56 (243)	12.8 (325)	381.6 (173)	
12 (300)		Class 150	16.8 (427)	17.3 (439)	11.38 (289)	13.7 (348)	300.3 (136)
		Class 300	18.0 (457)	18.7 (475)	11.38 (289)	13.7 (348)	417.5 (189)
	Class 600	20.5 (521)	20.7 (526)	11.38 (289)	13.7 (348)	596.5 (271)	
	PN 10	13.2 (335)	–	11.38 (289)	13.7 (348)	207.4 (94)	
	PN 16	13.9 (353)	–	11.38 (289)	13.7 (348)	227.7 (103)	
	PN 25	15.0 (381)	–	11.38 (289)	13.7 (348)	272.1 (123)	
	PN 40	16.9 (429)	–	11.38 (289)	13.7 (348)	350.0 (159)	
	PN 64	18.8 (478)	–	11.38 (289)	13.7 (348)	432.8 (196)	
	PN 100	21.2 (538)	–	11.38 (289)	13.7 (348)	645.1 (293)	
	JIS 10K	15.7 (399)	–	11.38 (289)	13.7 (348)	228.8 (104)	
	JIS 20K	15.7 (399)	–	11.38 (289)	13.7 (348)	291.4 (132)	
	JIS 40K	19.7 (500)	–	11.38 (289)	13.7 (348)	508.9 (231)	

(1) ±0.14 inch (3.6 mm)

(2) ±0.03 inch (0.8 mm)

(3) ±0.20 inch (5.1 mm)

(4) Add 0.4 Lb (0,2 kg) for display option.

FIGURE 7. Dimensional Drawings for Remote Mount Transmitters

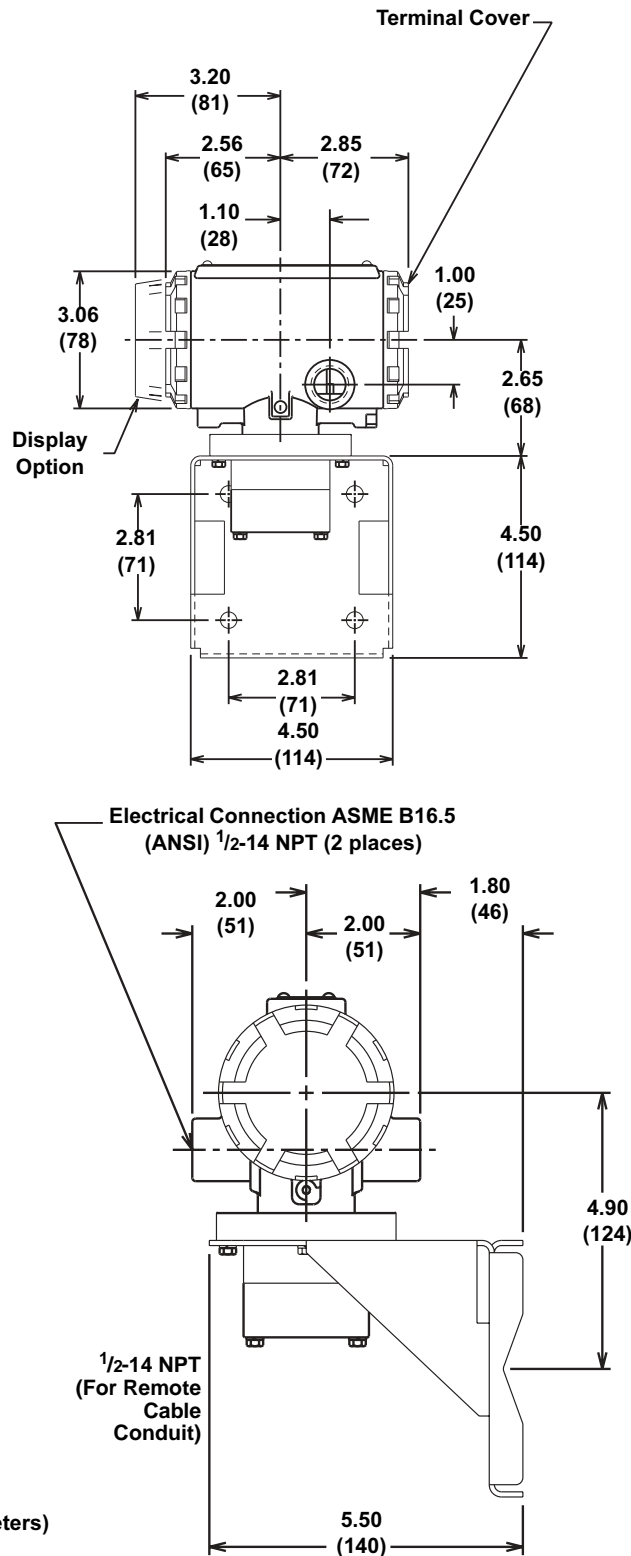

NOTE
 Dimensions are in inches (millimeters)

8800-8800_34AA, 8800_35AA.EPS

FIGURE 8. Dimensional Drawings for Remote Mount Wafer-Style Flowmeters
 (1/2-through 8-inch/15 through 200 mm Line Sizes)

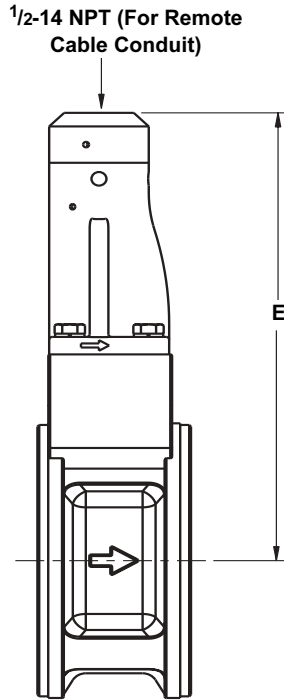

NOTE
 Dimensions are in inches (millimeters)

8800-8800_36AA.EPS

TABLE 27. Rosemount 8800C Wafer-Style Meter

Nominal Size Inch (mm)	E Wafer Style Inch (mm)
1/2 (15)	6.4 (163)
1 (25)	6.5 (165)
1 1/2 (40)	6.9 (175)
2 (50)	7.6 (193)
3 (80)	8.3 (211)
4 (100)	9.2 (234)
6 (150)	9.5 (241)
8 (200)	10.4 (264)

FIGURE 9. Dimensional Drawings for Flanged-and Dual Sensor Flanged-Style Remote Mount Flowmeters
 (1/2-through 12-inch/15 through 300 mm Line Sizes)

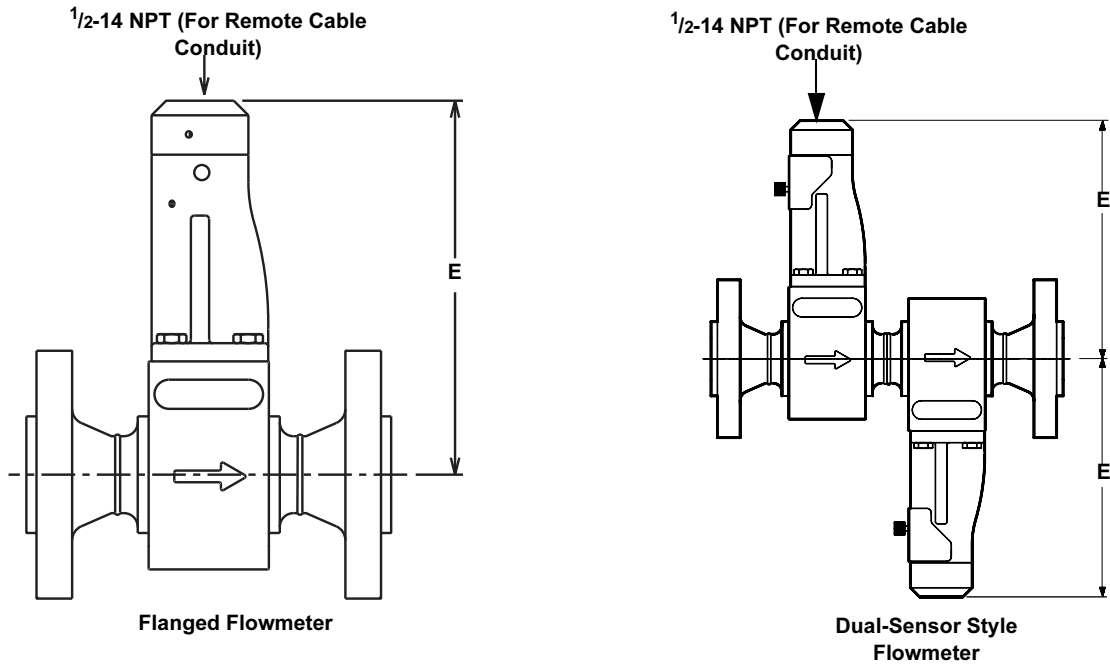

NOTE
 Dimensions are in inches (millimeters)

8800-8800_37AA, 0006C03A

TABLE 28. Remote Mount, Flanged-and Dual Sensor Flowmeter Dimensions

Nominal Size Inch (mm)	E Flange Style Inch (mm)
1/2 (15)	6.4 (162)
1 (25)	6.5 (165)
1 1/2 (40)	6.8 (173)
2 (50)	7.2 (183)
3 (80)	7.8 (198)
4 (100)	8.3 (211)
6 (150)	9.5 (241)
8 (200)	10.4 (264)
10 (250)	11.4 (290)
12 (300)	12.3 (313)

Ordering Information

Model	Product Description
8800C	Vortex Flowmeter
Code	Meter Style
W	Wafer style
F	Flanged style
R	Reducer Style (Flanged style only)
D	Dual-sensor style (Flanged style only)
Code	Line Size
005	1/2 Inch (15 mm) (Not available for Rosemount 8800CR)
010	1 Inch (25 mm)
015	1 1/2 Inches (40 mm)
020	2 Inches (50 mm)
030	3 Inches (80 mm)
040	4 Inches (100 mm)
060	6 Inches (150 mm)
080	8 Inches (200 mm)
100	10 Inches (250mm)
120	12 Inches (300mm)
Code	Wetted Materials
S	316L wrought stainless and CF-3M cast stainless
H	C-22 [®] and C-276 wrought <i>Hastelloy</i> [®] ; CW2M and CW12MW cast <i>Hastelloy</i> [®] Note: See Table 29 on page 37
Code	Flange or Alignment Ring Size
A1	ASME B16.5 (ANSI) RF Class 150
A3	ASME B16.5 (ANSI) RF Class 300
A6	ASME B16.5 (ANSI) RF Class 600
A7	ASME B16.5 (ANSI) RF Class 900
A8 ⁽¹⁾	ASME B16.5 (ANSI) RF Class 1500
B1	ASME B16.5 (ANSI) RTJ Class 150 for flange-style only
B3	ASME B16.5 (ANSI) RTJ Class 300 for flange-style only
B6	ASME B16.5 (ANSI) RTJ Class 600 for flange-style only
B7	ASME B16.5 (ANSI) RTJ Class 900 for flange-style only
B8 ⁽¹⁾	ASME B16.5 (ANSI) RTJ Class 1500 for flange-style only
C1	ASME B16.5 (ANSI) RF Class 150, smooth finish
C3	ASME B16.5 (ANSI) RF Class 300, smooth finish
C6	ASME B16.5 (ANSI) RF Class 600, smooth finish
C7	ASME B16.5 (ANSI) RF Class 900, smooth finish
D0	DIN PN 10 2526-Type D
D1	DIN PN 16 (PN 10/16 for wafer-style)2526-Type D
D2	DIN PN 25 2526-Type D
D3	DIN PN 40 (PN 25/40 for wafer-style) 2526-Type D
D4	DIN PN 64 2526-Type D
D6	DIN PN 100 2526-Type D
D7	DIN PN 160 2526-Type D
G0	DIN PN 10 2512-Type N for flange-style only
G1	DIN PN 16 2512-Type N for flange-style only
G2	DIN PN 25 2512-Type N for flange-style only
G3	DIN PN 40 2512-Type N for flange-style only
G4	DIN PN 64 2512-Type N for flange-style only
G6	DIN PN 100 2512-Type N for flange-style only
G7	DIN PN 160 2512-Type N for flange-style only

Continued on Next Page

Code	Flange or Alignment Ring Size
H0	DIN PN 10 2526-Type E
H1	DIN PN 16 (PN 10/16 for wafer-style) 2526-Type E
H2	DIN PN 25 2526-Type E
H3	DIN PN 40 (PN 25/40 for wafer-style) 2526-Type E
H4	DIN PN 64 2526-Type E
H6 ⁽³⁾	DIN PN 100 2526-Type E
H7	DIN PN 160 2526-Type E
J1	JIS 10K
J2	JIS 20K
J4	JIS 40K
Code	Sensor Process Temperature Range
N	Standard: -40 to 450°F (-40 to 232°C)
E	Extended: -330 to 800°F (-200 to 427°C)
Code	Conduit Entry
1	1/2 -14 NPT
2	M20 × 1.5
3	PG 13.5
Code	Outputs
D	4-20 mA digital electronics (Hart [®] protocol)
P	4-20 mA digital electronics (Hart [®] protocol) with scaled pulse
F	FOUNDATION fieldbus digital signal ⁽²⁾
Code	Calibration
1	Flow calibration
Code	Options
Hazardous Locations Certifications	
E5	Factory Mutual (FM) Explosion-Proof approval
I5	Factory Mutual (FM) intrinsic safety approval
IE	Factory Mutual (FM) Fisco ⁽³⁾
K5	Factory Mutual (FM) E5 and I5 combination approval
I1	ATEX / BASEEFA Intrinsic safety and dust certification
IA	ATEX / BASEEFA Fisco
N1	ATEX / BASEEFA Type n certification
E1	ATEX / KEMA Flame-Proof certification
E6	Canadian Standards Association (CSA) Explosion-Proof approval
I6	Canadian Standards Association (CSA) intrinsic safety approval
IF	Canadian Standards Association (CSA) Fisco
C6	Canadian Standards Association (CSA) E6 and I6 combination approval
E7	IEC Ex Standards Association of Australia (SAA) flameproof certification (pending final approval)
I7	IEC Ex Standards Association of Australia (SAA) intrinsic safety certification (pending final approval)
N7	IEC Ex Standards Association of Australia (SAA) Type N certification (pending final approval)
Plantweb Functionality	
A01	Basic Control: One Proportional/Integral/Derivative (PID) Function Block
Conduit Electrical Connector	
GE ⁽⁴⁾	M12, 4-pin, Male Connector (<i>euromast</i> [®])
GM ⁽⁵⁾	A size Mini, 4-pin, Male Connector (<i>minifast</i> [®])

Continued on Next Page

Options Continue	
Other Options	
M5	LCD indicator
P2	Cleaning for special services
C4 ⁽⁵⁾	Analog output levels compliant with NAMUR recommendation NE43, 18-January-1994 and high alarm level
CN ⁽⁴⁾	Analog output levels compliant with NAMUR recommendation NE43, 18-January-1994 and low alarm level
R10	Remote electronics with 10 ft (3,0 m) cable
R20	Remote electronics with 20 ft (6,1 m) cable
R30	Remote electronics with 30 ft (9,1 m) cable
RXX ⁽⁶⁾	Remote electronics with customer-specified cable length (up to 75 ft (23 m) maximum)
T1	Transient protection terminal block
V5 ⁽⁷⁾	External ground screw assembly
Certification Options	
Q4	Calibration data sheet per ISO 10474 3.1.B
Q8	Material traceability certification per ISO 10474 3.1.B
Q14 ⁽⁸⁾	German TRB 801 Nr.45 certification per ISO 10474 3.1.B
Q69 ⁽⁹⁾	Inspection certificate weld examination (wafer) per ISO 10474 3.1.B
Q70	Inspection certificate weld examination (flanged) per ISO 10474 3.1.B
Q71	Inspection certification weld examination (flanged) per ISO 10474 3.1.B (includes x-rays)
Typical Model Number: 8800C F 020 S A1 N 1 D 1 M5	

- (1) Only available for stainless steel flange style meters. Not available in 1/2-in. (15 mm).
- (2) Includes one analog input (AI) function block and Backup Link Active Scheduler.
- (3) Fieldbus Intrinsic Safe Concept available with F (FOUNDATION fieldbus digital signal) output code only.
- (4) Not available with certain hazardous location certifications. Contact a Rosemount representative for details.
- (5) NAMUR compliant operation and the alarm latch options are pre-set at the factory and cannot be changed to standard operation in the field.
- (6) XX is a customer specified length in feet.
- (7) V5 only available with no approval or E5, I5, K5, E6, I6, and C6; it is standard with the other approvals.
- (8) Q14 is not available with flange codes A7, A8, B7, B8, C7, D7, G7, H7, 10in.-12in. meters, and 8800CR Reducer Vortex.
- (9) Q69 available for all Hastelloy® wafers and stainless steel wafers in line sizes 1/2-in. (15 mm), 6-in. (150 mm), and 8-in. (200 mm).

TABLE 29. Method of Construction for the 8800CF in Hastelloy-C Material

Line Size	A1	A3	A6	D1	D3	D4	D6
1/2 (15)	C	C	C	W	W	NA	W
1 (25)	C	C	C	W	W	NA	W
1 1/2 (40)	C	C	C	W	W	NA	W
2 (50)	C	C	C	C	C	CF	W
3 (80)	C	C	C	C	C	CF	W
4 (100)	C	C	C	C	C	CF	W
6 (150)	W	W	W	W	W	CF	W
8 (200)	W	W	W	W	W	CF	W
10 (250)	W	W	W	W	W	W	W
12 (300)	W	W	W	W	W	W	W

C = Hastelloy C-22 collar and 316 SST lap flange. If weld neck flange is required, V0022 can be ordered.
 W = Hastelloy C-22 weld neck flange.
 CF = Consult factory
 NA = Not available

Product Data Sheet

00813-0100-4003, Rev MB
August 2004

Rosemount 8800C

*Rosemount and the Rosemount logotype are registered trademarks of Rosemount Inc.
PlantWeb is a mark of one of the Emerson Process Management companies.
All other marks are the property of their respective owners.*

Approved by the Committee of Russian Federation for Standardization, Metrology and Certification (the Gosstandart of Russia) and registered in the Russian State Register of measuring instruments.

Reducer Vortex is a trademark of Rosemount Inc.

MultiVariable (MV) is a trademark of Rosemount Inc.

Annubar is a registered trademark of Dieterich Standard Inc.

Mass ProBar and ProBar are trademarks of Dieterich Standard Inc.

HART is a registered trademark of the HART Communication Foundation.

FOUNDATION is a trademark of the Fieldbus Foundation.

Hastelloy and Hastelloy C-22 are registered trademarks of Haynes International Inc

Cover Photo: 8800-8800k921



Emerson Process Management

Rosemount Inc.

8200 Market Boulevard
Chanhassen, MN 55317 USA
T 1-800-999-9307
T (International) (952) 906-8888
F (952) 949-7001

www.rosemount.com



Fisher-Rosemount Flow

Groeneveldselaan 6-8
3903 AZ Veenendaal
The Netherlands
Tel 31 (0) 318 549 549
Fax 31 (0) 318 549 559
Tel 0800-966-180 (U.K. only)
Fax 0800-966-181 (U.K. only)

Emerson Process Management Asia Pacific Private Limited

1 Pandan Crescent
Singapore 128461
T (65) 777 8211
F (65) 777 0947
AP.RMT-Specialist@emersonprocess.com